



# User Guide

KLK.FRANCE

## Welcome To **MAKE.PLAN!**

This version of the application is an initial release, dedicated to private beta testing. It is provided to you free of charge to explore and test the application's features. We thank you for your participation and feedback, which will help us improve and perfect Make.Plan. Feel free to share your comments and suggestions.

Your opinion matters to us, thank you for your trust!

# Table Of Contents

<b>I. Introduction</b>	<b>1.</b>	8. Additional Features	<b>12.</b>
<b>II. Getting Started</b>	<b>2.</b>	9. Statistics and General Data	<b>14.</b>
1. Installation and Initial Setup	<b>2.</b>	<b>V. Drawing Features and Advanced Options</b>	<b>15.</b>
a. Downloading the Application	<b>2.</b>	1. Drawing Tools	<b>15.</b>
b. Compatible Devices	<b>2.</b>	2. Display Modes	<b>16.</b>
2. Creating an Account (Sign Up)	<b>2.</b>	3. Display Modes	<b>16.</b>
3. Logging into Your Account	<b>3.</b>	4. Precise Measurements	<b>17.</b>
<b>III. Using the Application</b>	<b>4.</b>	5. Plan Interaction	<b>17.</b>
1. Navigating the Application	<b>4.</b>	6. Element Modification and Information	<b>18.</b>
a. Home Page	<b>4.</b>	7. Compatibility with Digital Libraries	<b>18.</b>
b. Managing Floors	<b>5.</b>	8. Export Types	<b>18.</b>
<b>IV. Scan Features and Components</b>	<b>6.</b>	<b>VI. Settings Section</b>	<b>20.</b>
1. Scan Plan Steps	<b>6.</b>	1. Account	<b>20.</b>
2. Validation and Post-Scan Options	<b>8.</b>	2. About	<b>21.</b>
3. Post-Generation Interface	<b>9.</b>	3. Language Configuration	<b>22.</b>
4. Drawing Cursor Control	<b>10.</b>	4. Account Actions	<b>22.</b>
5. Available Layers	<b>10.</b>	5. Useful Links	<b>22.</b>
6. Tips for a Successful Scan	<b>11.</b>	<b>VII. Support</b>	<b>23.</b>
7. Scan and Plan Management	<b>11.</b>		

# Introduction

Welcome to MAKE.PLAN, the innovative application revolutionizing 2D plan creation and 3D model design. With advanced features and an intuitive interface, MAKE.PLAN allows you to:

- Generate plans and models quickly and accurately.
- Perform dimension, area, and volume measurements.
- Produce detailed reports tailored to various building professions.

## Who is MAKE.PLAN for?

Whether you are an architect, designer, real estate agent, inspector, construction company, or a professional in the real estate sector, MAKE.PLAN meets your needs with flexible management, collaboration, and export options.

# Getting Started

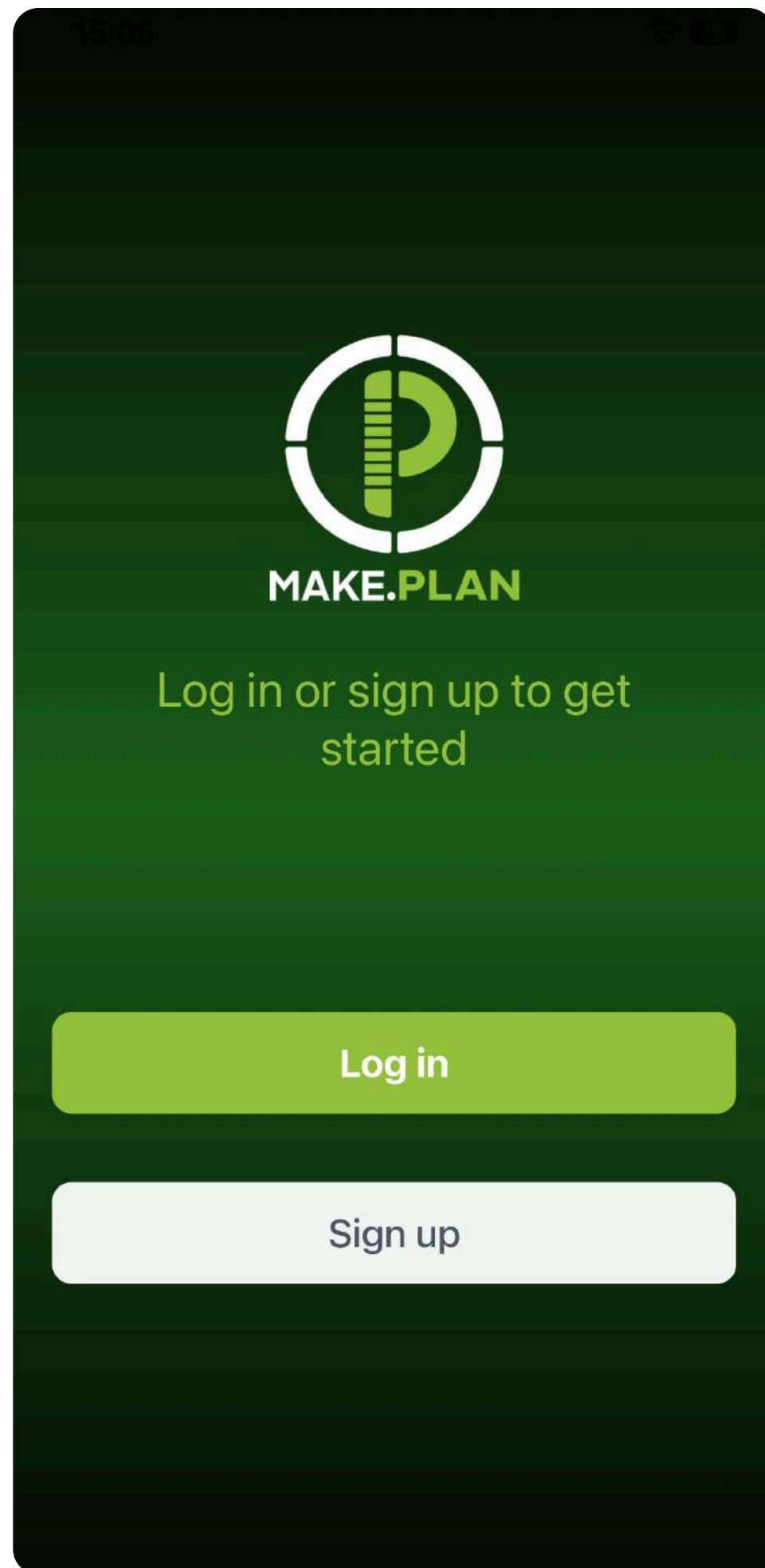

## 1. Installation and Initial Setup

### a. Downloading the Application

On iOS: Go to the App Store, search for "MAKE.PLAN," and download and install the application.

### b. Compatible Devices

The application is compatible with the following models :

- iPhone 12 Pro et Pro Max
- iPhone 13 Pro et Pro Max
- iPhone 14 Pro et Pro Max
- iPhone 15 Pro et Pro Max
- iPhone 16 Pro et Pro Max
- iPad Pro 11
- iPad Pro 12.9
- iPad Pro 13

Ensure your device has the required iOS version to guarantee a smooth and optimal experience.

Note: If you own a device not listed above, you can still use the application and access all its features except for the SCAN function, which requires a Lidar. All other features, including project consultation, remain fully accessible.

< Back

## 2. Creating an Account (Sign Up)

a. Launch the application and select the "Sign Up" option.

b. Fill in the required fields: **Username, Email, and Password.** A validation email will be sent to the provided address.

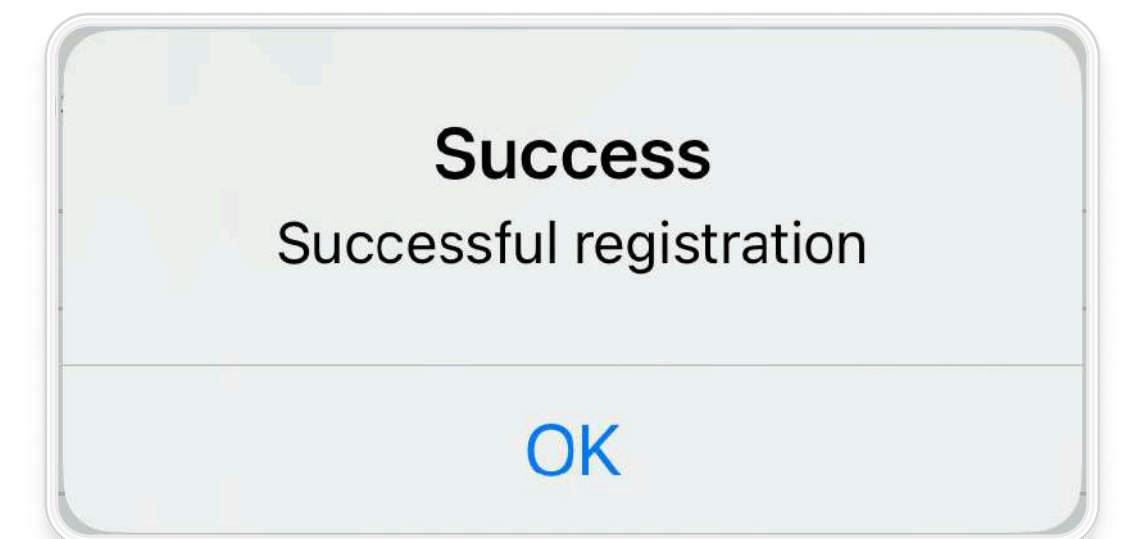

# Getting Started

Open the email, retrieve the OTP code, and enter it in the application to validate your account.

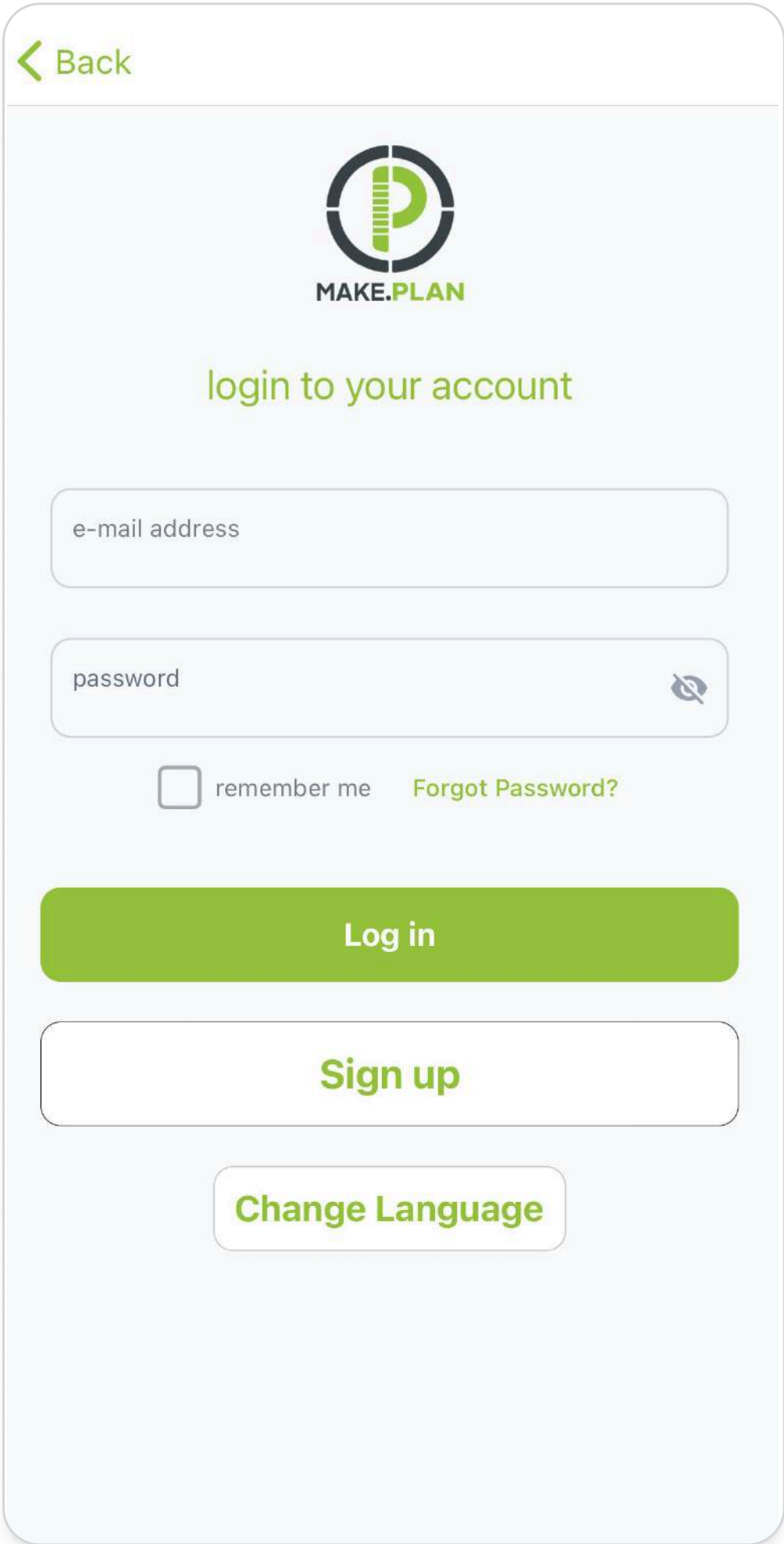
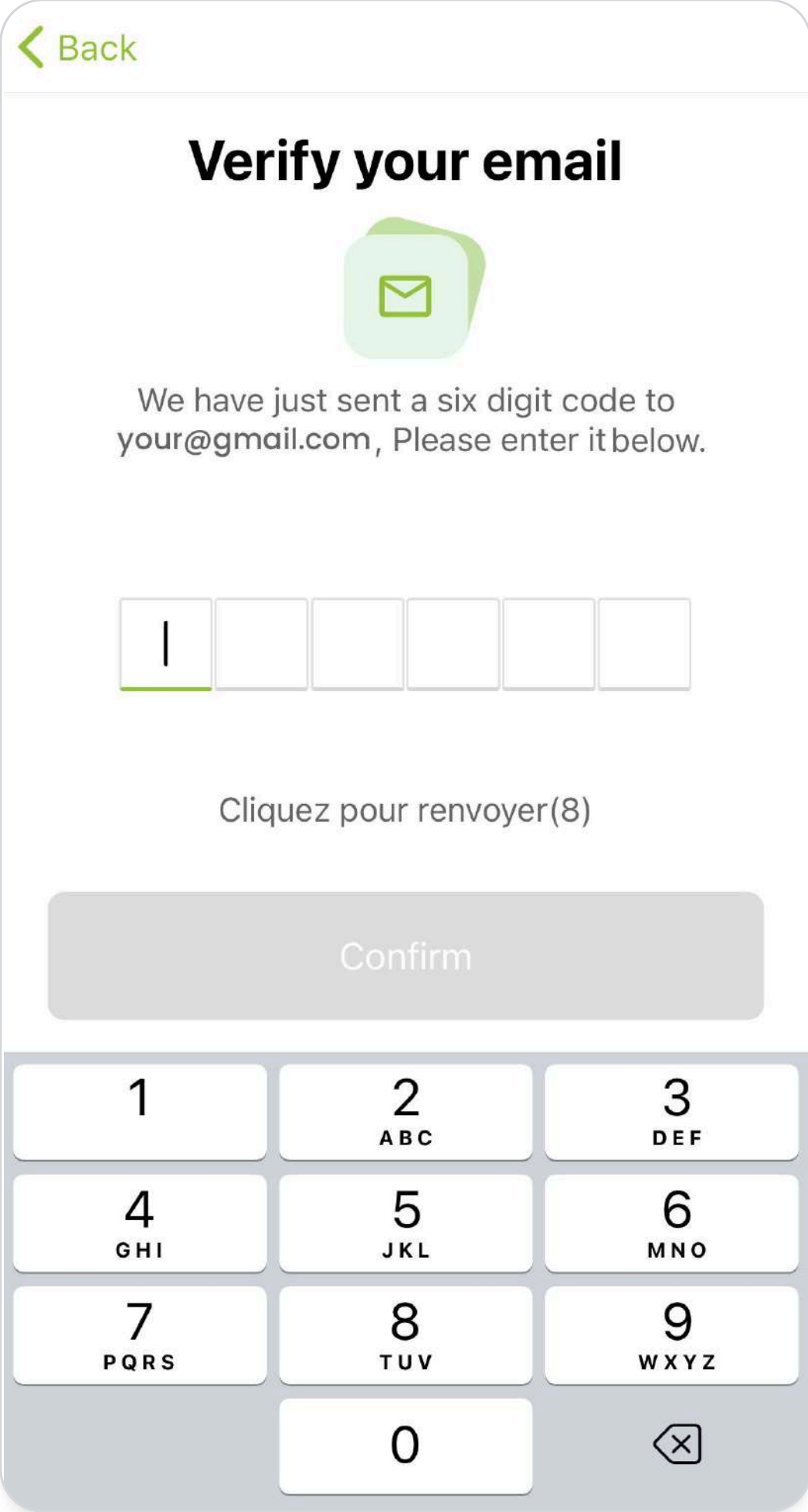

### 3. Logging into Your Account

#### a. Login Process

- Click the "**Login**" button on the home screen.
- In the designated fields, enter:
  - Your email address
  - Your **Password**
- For easier access during future visits, check the "**Remember me**" box.

Note: If you forget your password, use the "**Forgot Password?**" option to reset it.

#### b. Language Customization

- The interface is available in three languages:
  - French
  - English
  - Spanish
- To change the language, locate the "**Change Language**" button at the bottom of the screen and select your preferred language.

# Using the Application

For an optimal experience and access to all features, an internet connection is required while using the application. Ensure you are connected to interact with maps, modify elements, or download real-time data.

## 1. Navigating the Application

### a. Home Page

After logging in, you are directed to the home page, where all your created projects are displayed. Key options include:

#### Search for a Project

Use the **search bar** to quickly locate an existing project.

#### Project Visualization

Each project is displayed as a box containing:

- **Photo** of the project's exact geolocation.
- **Project name** (editable).
- **Creation date**.

#### Delete a Project

1. Long-press on the project you wish to delete.
2. Confirm the deletion when prompted.

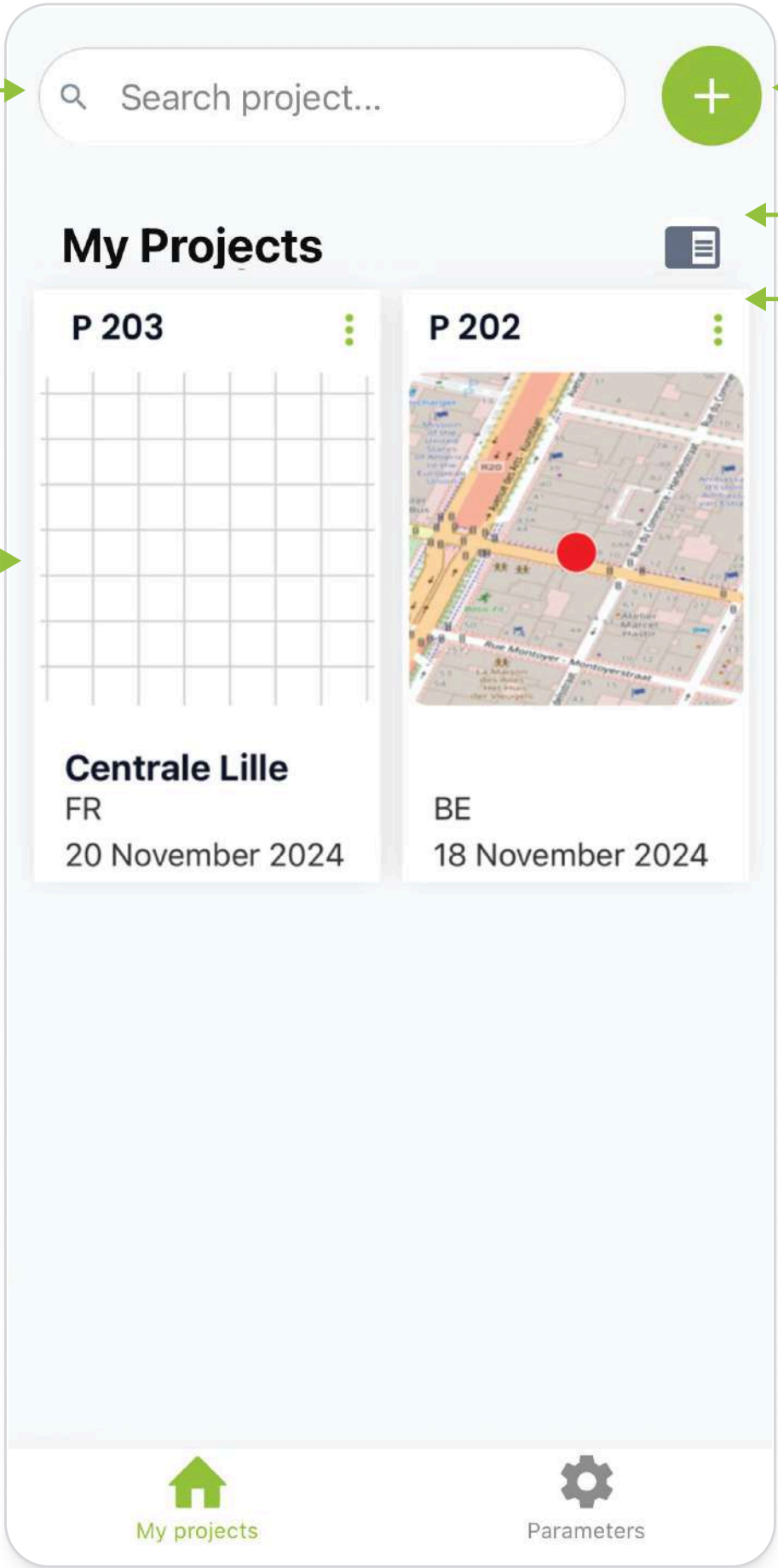
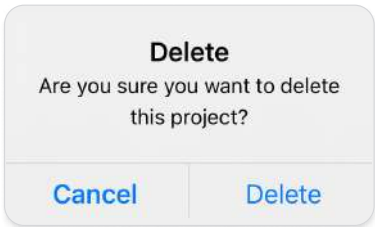

#### Add a New Project

1. Click the "+" button at the top of the screen to create a new project.
2. Name the project and start adding details when ready.

#### Guide Mode

For additional information during navigation:

- Click this button to enable guide mode.
- Contextual assistance will appear in real time, guiding you through each step of your usage.
- Explanations automatically adapt to the section you are currently viewing in the application.

#### Edit a Project

Click the three dots next to the project name to rename it.

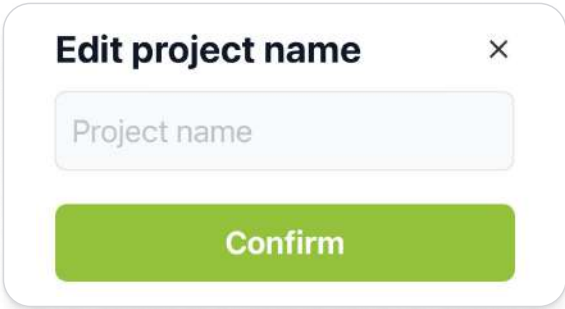

# Using the Application

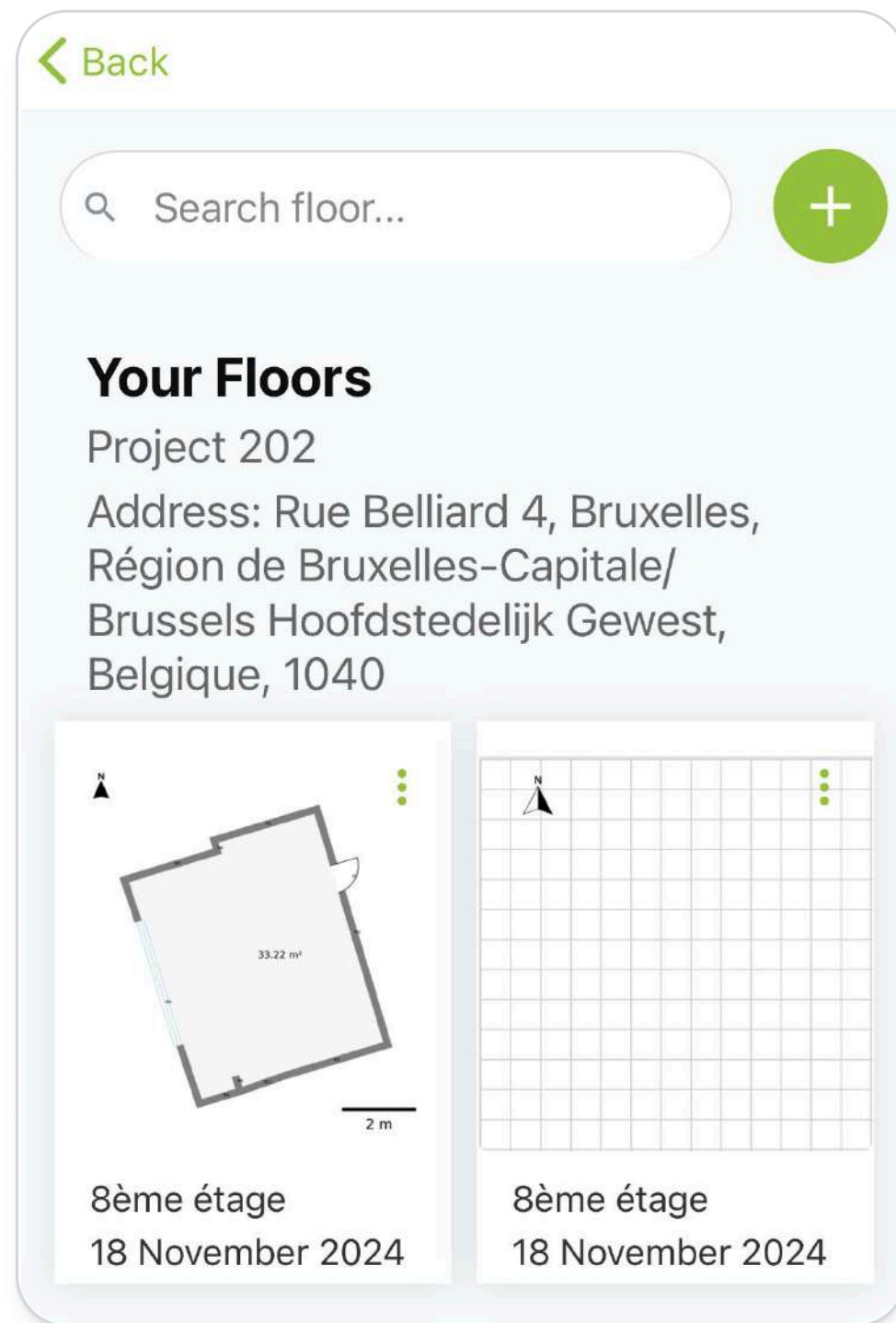

## b. Managing Floors

### Accessing Project Floors

Click on a project to display the list of floors created within it.

### Adding a Floor

Tap the "+" button to create a new floor in the selected project.

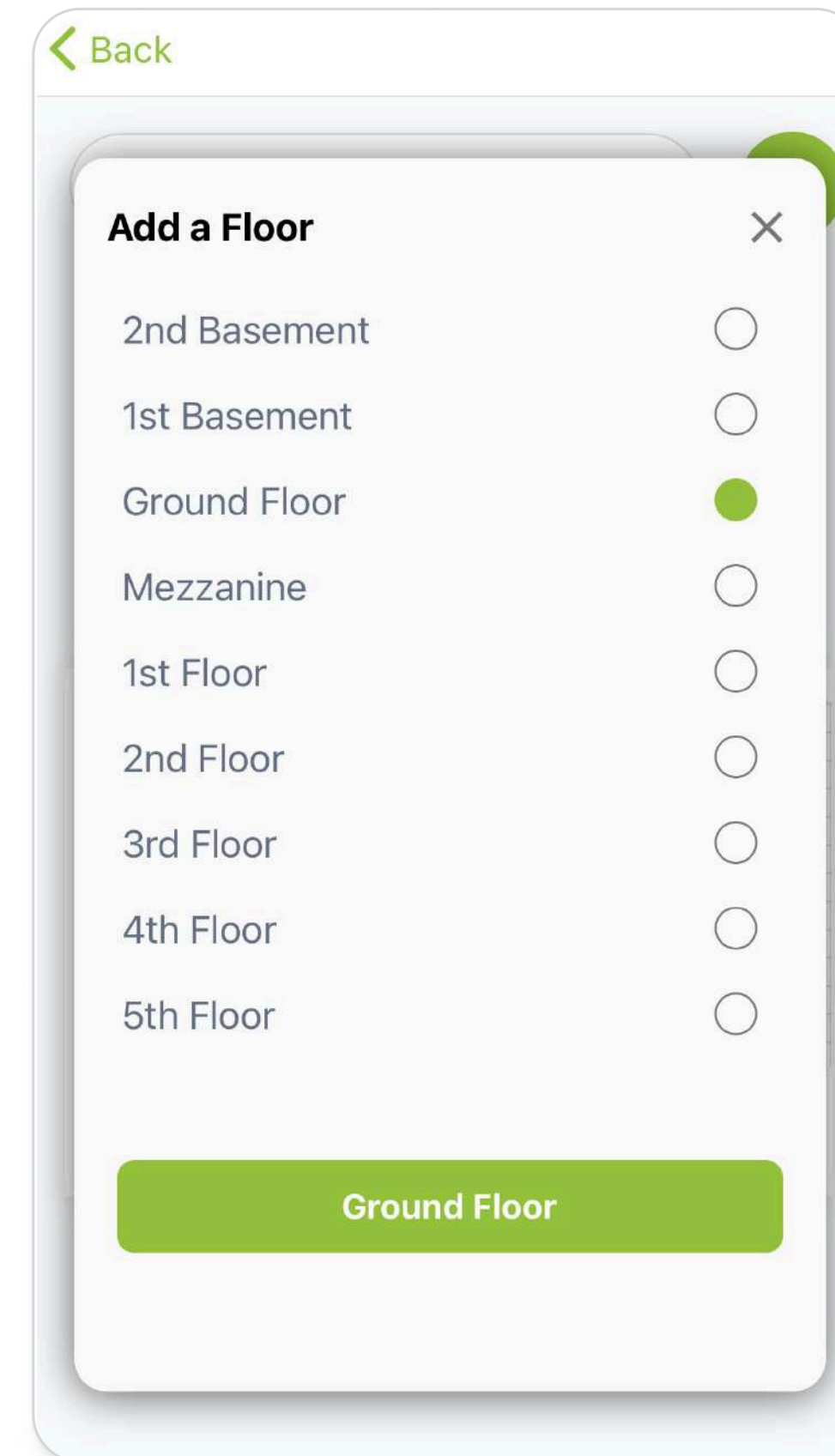

## Visualizing and Editing a Floor

Select a floor to access its content and start working on it. You will be redirected to a dedicated drawing interface.



# Scan Features and Components

## Scan Plan

When you select a floor, a dedicated interface opens with an interactive toolbar at the bottom. Among the features is the "Scan Plan" button, which initiates an intuitive and guided scanning process.

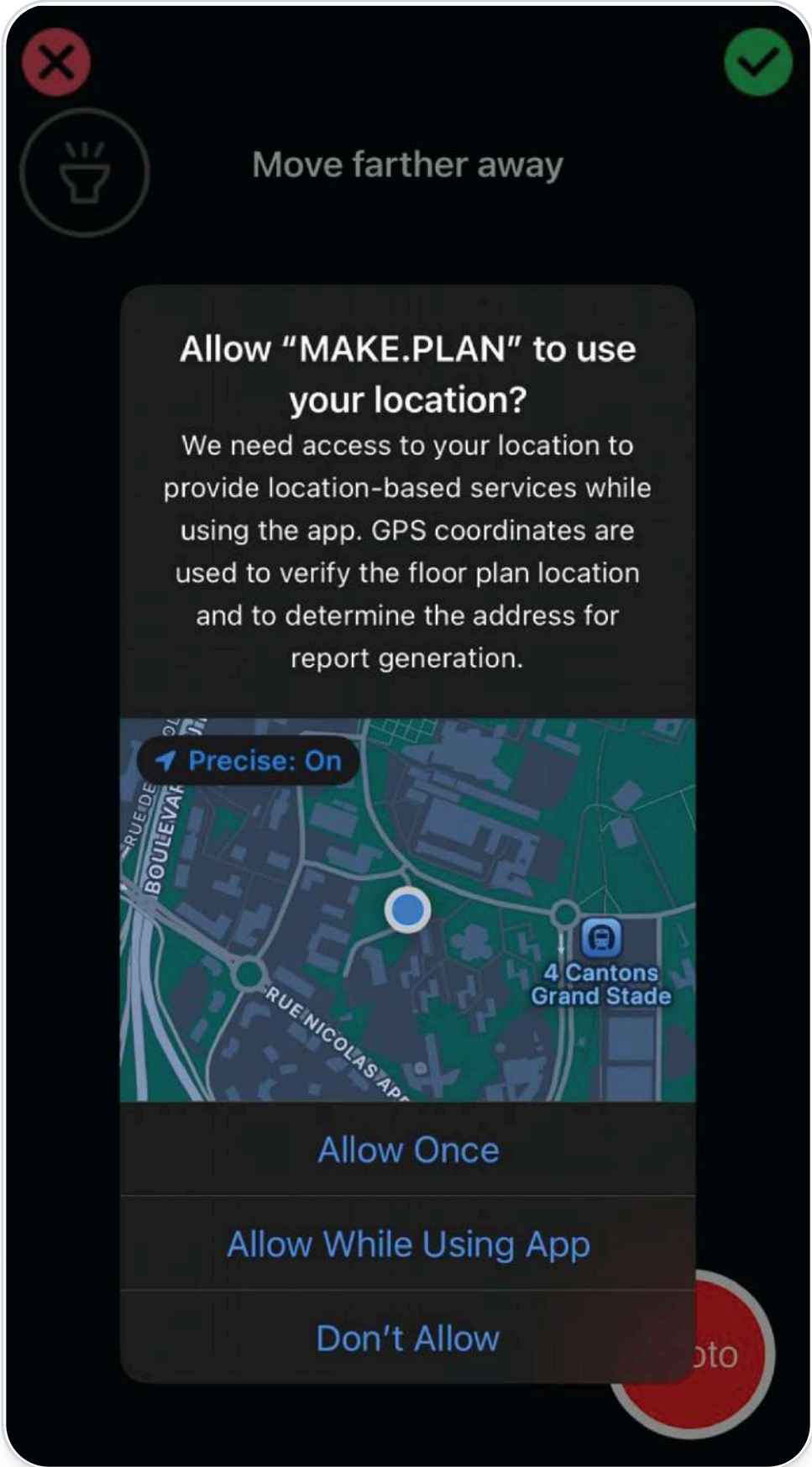
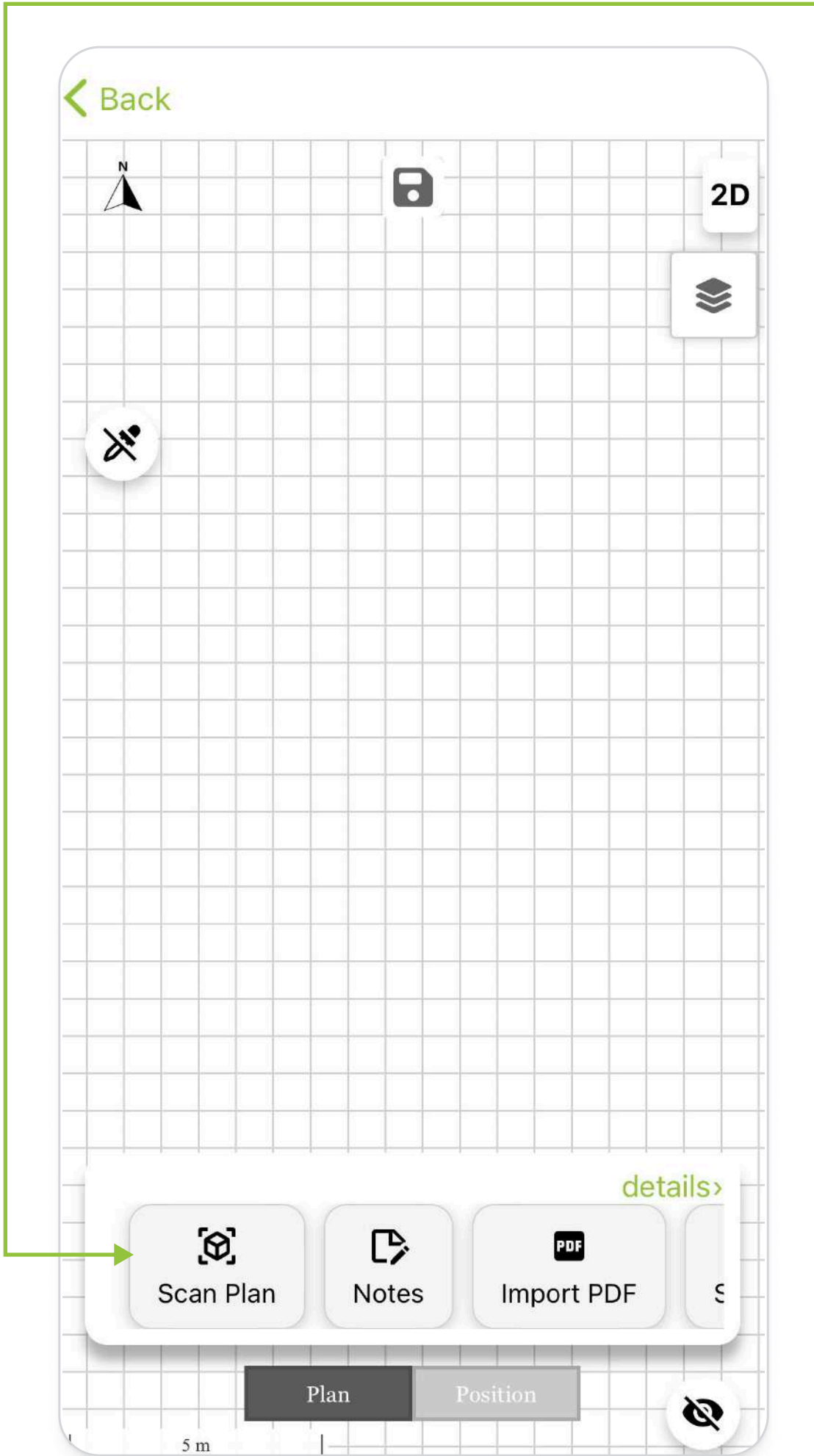

### 1. Scan Plan Steps:

#### a. Location Activation:

To optimize the app's functionality, it is crucial to enable location services on your device. This feature allows the app to accurately detect your geographic coordinates, enabling you to position your scanned plan with maximum precision, aligning it perfectly with its real location. Activating location services ensures an enriched experience and accurate mapping, essential for professional and reliable results. Tip: Ensure your GPS is active before starting to make the most of this feature.

# Scan Features and Components

  
**Instruction**  
Click the red button to start the scanning process.

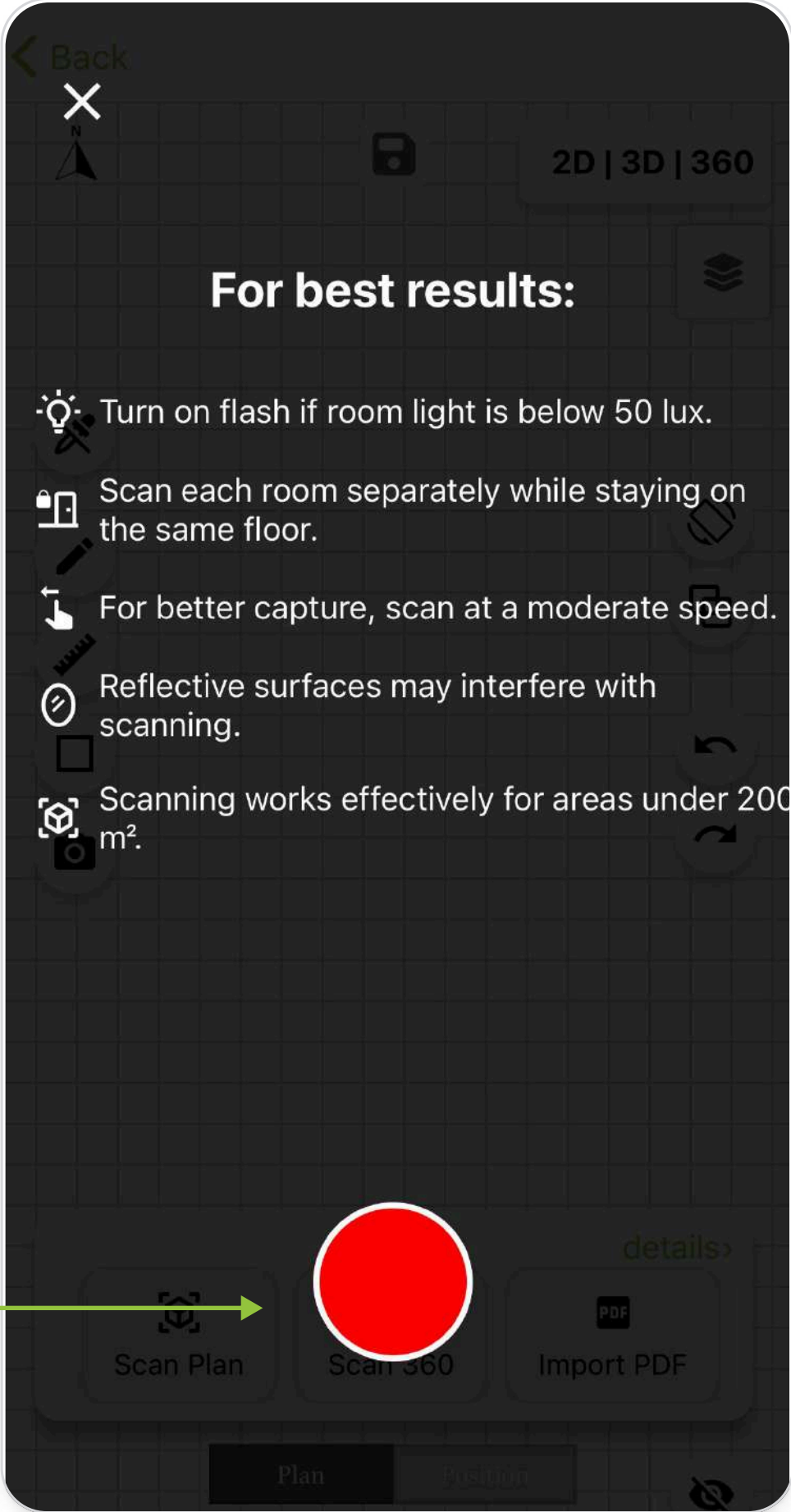

## b. Launching the Scan Guide

Upon clicking "**Scan Plan**," an interactive guide appears to walk you through the steps needed for an accurate scan.

This guide provides clear instructions to help you capture high-quality scans, ensuring a faithful 3D model representation.

# Scan Features and Components



## c. Capture and Real-Time View:

1. During the scan, an **interactive 3D model** is displayed in real-time, allowing you to monitor the collected data.
2. A **"Photo" button** is available during the scanning process to capture specific images. Each photo is automatically geolocated on the plan. After the scan, you can adjust the shooting direction and location. This feature is ideal for documenting specific elements such as architectural details, equipment, or defects while maintaining their spatial positioning within the overall plan.
3. For low-light conditions, activate the **flash** option to enhance image quality.

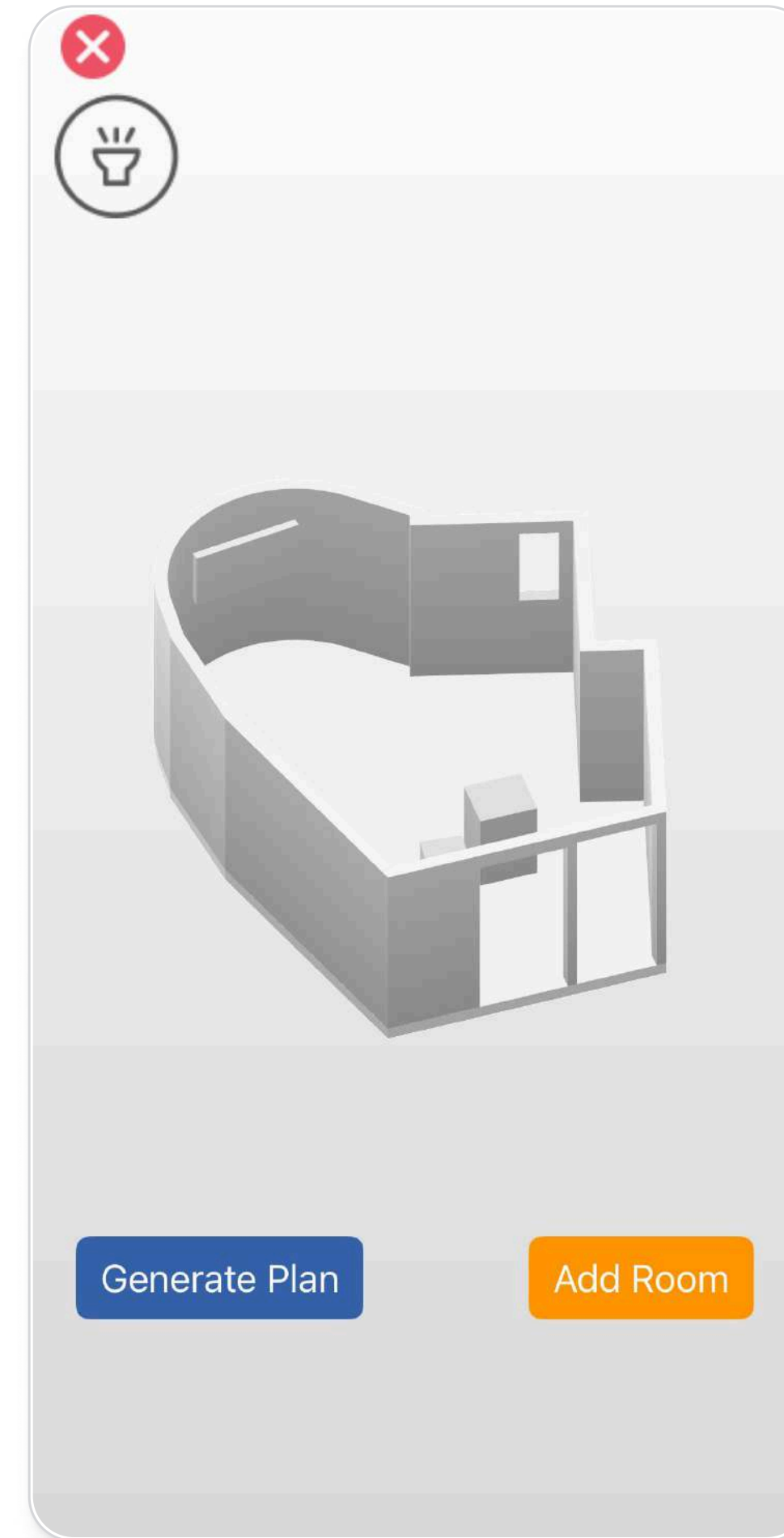

## 2. Validation and Post-Scan Options:

Once your scan is validated, you have two options:

1. **Add Another Room:** Scan an additional room and merge its data with the existing plan.
2. **Generate Plan:** Create a detailed 2D plan from the collected data.



# Scan Features and Components

## 4. Drawing Cursor Control

The cursor control is essential for precise work



- **Select** : Click to choose an element, area to modify, or part to draw on.
- **Move** : Hold and drag to adjust objects.
- **Visual Guides** : Use automatic alignment lines for a polished result.
- **Validate** : Click "Validate" to confirm your drawing.
- **Hide** : Hide the cursor by clicking the eye icon.
- **Delete** : Remove the drawing by clicking the cross icon

*Tip: Take time to experiment with the controls to master them and achieve reliable results.*

## 5. Available Layers

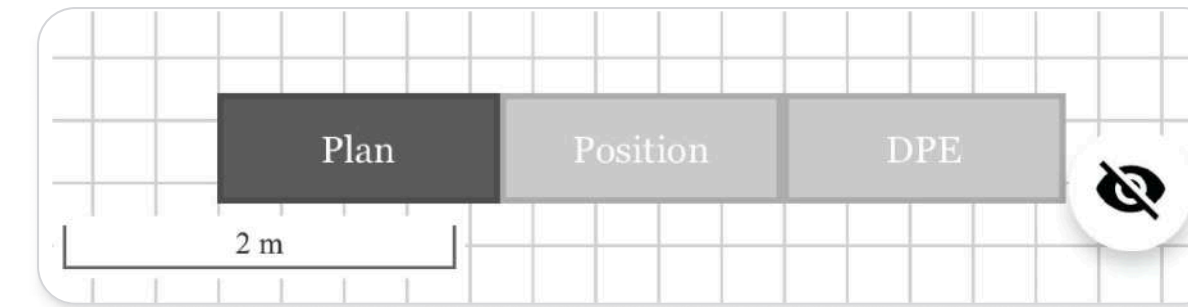

- **Plan** : Displays the 2D plan clearly and neatly.
- **Position**:
  - Shows the plan's exact geographic location with three map backgrounds available:
    - i. World Map ESRI
    - ii. OpenStreetMap (OSM)
    - iii. IGN
    - iv. A cadastral layer is available in France.
  - Additional options:
    - i. Capture a 2D screenshot of the geographic location.
    - ii. Adjust the plan's orientation.

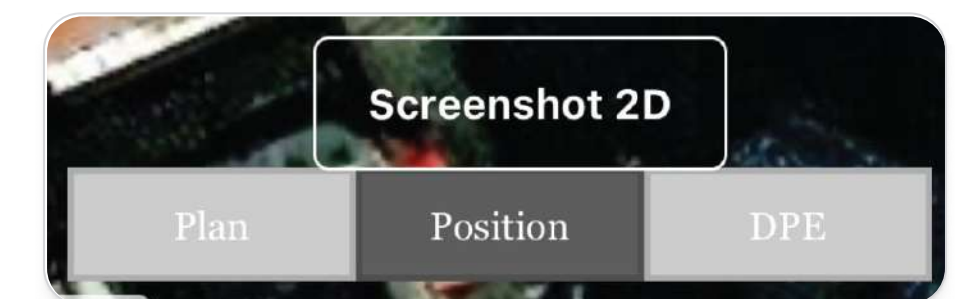
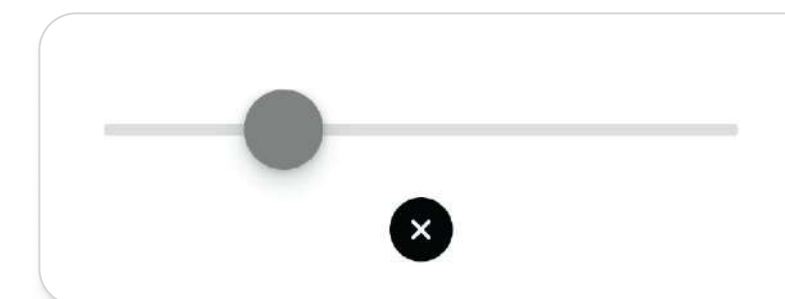
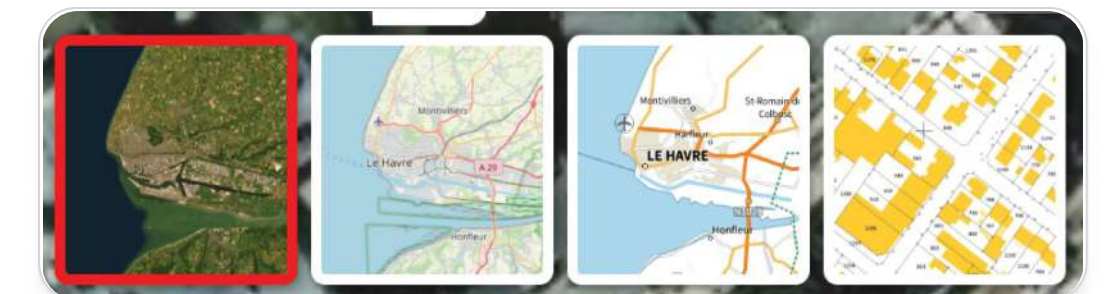

# Scan Features and Components

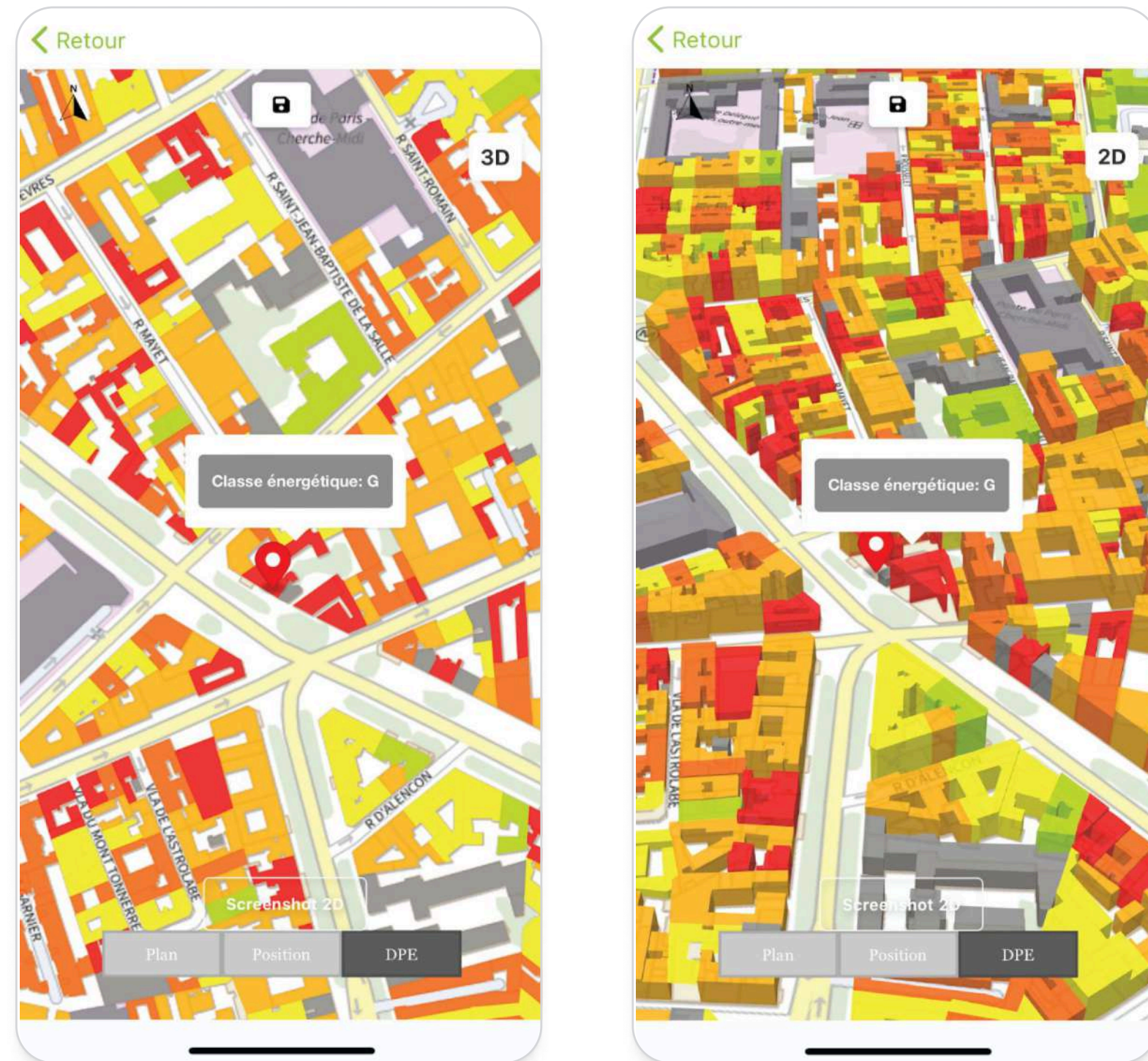

- **DPE** :A layer dedicated to evaluating the building's energy performance. This feature is available only in France and displays the energy class of buildings according to local standards.

*If the location icon is not directly on a building, adjust it to match the actual building location for accurate energy class information.*

## 6. Tips for a Successful Scan

To optimize your results during the scan, follow these recommendations:

- **Lighting:** Ensure the area is well-lit to avoid shadows or capture errors. Activate the flash if necessary.
- **Stability:** Keep the device steady for sharp images and accurate measurements.
- **Alignment:** Follow the visual guides displayed in the app to align each shot correctly.
- **Revisions:** Regularly check the real-time 3D model to correct inaccuracies before validating the scan.

## 7. Scan and Plan Management

Once scans are completed, MAKE.PLAN offers powerful tools:

- **Automatic Scan Merging:** Combine multiple scans to create a comprehensive and consistent plan.
- **Post-Scan Modifications:**
  - Adjust dimensions and correct errors.
  - Add annotations to enrich your plans (text, photos, etc.)

These adjustments can be made directly through the drawing interface, which also allows for precise zooming on critical areas.

# Scan Features and Components

## 8. Additional Features

- **Scan 360°** : Connect a Ricoh device for immersive panoramic scans.

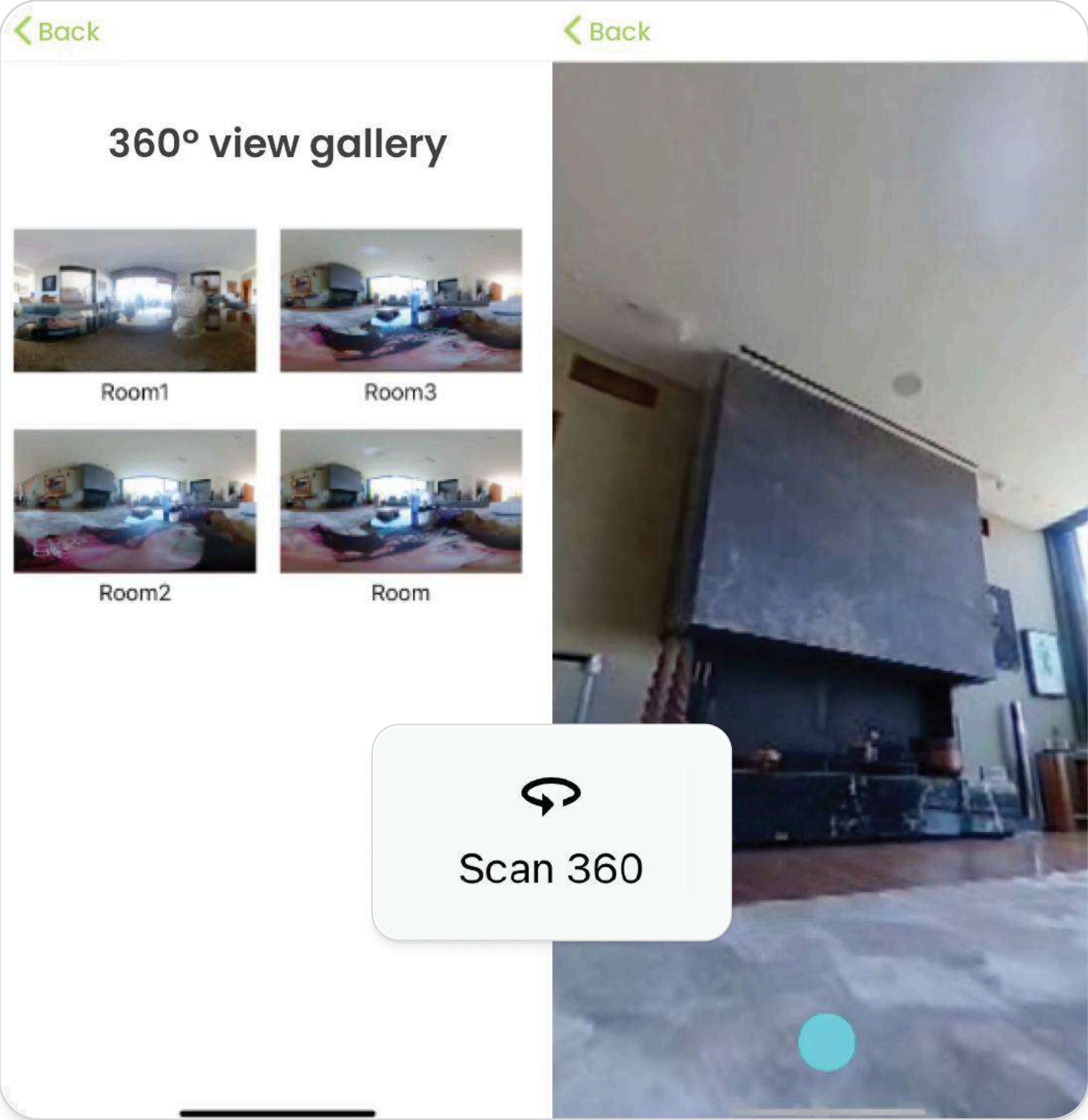

- **File Import**: Import PDF or image files (JPEG, PNG) to draw directly on them with optimal precision.





- 1) Dimension Identification**: After importing, identify a section of the file with known real dimensions.
- 2) Cursor Activation**: Enable the cursor to select this specific section.
- 3) Measurement Input**: Enter the real dimensions of the selected section.
- 4) Real Scale Conversion**: The plan is automatically adjusted to reflect real dimensions and scale.

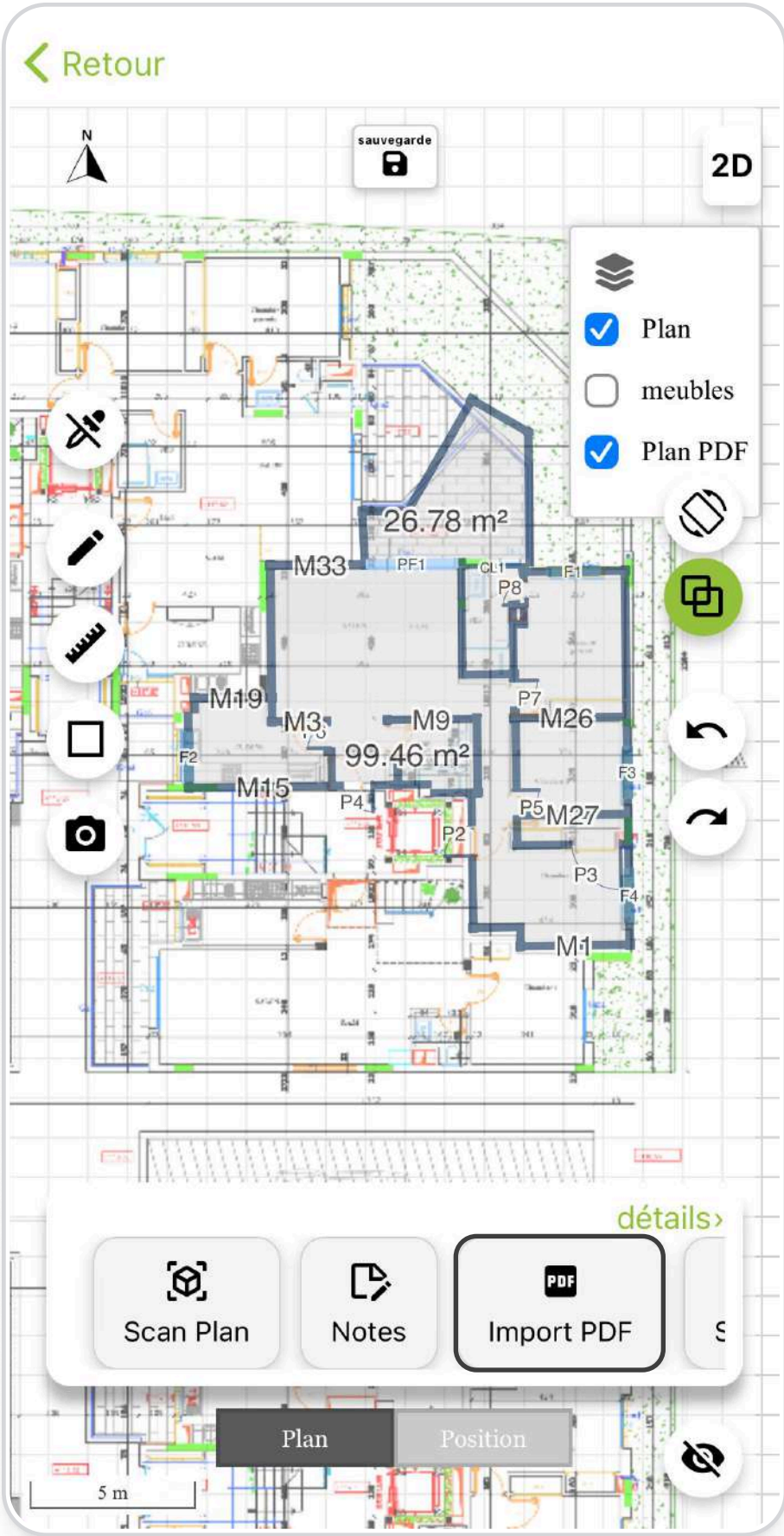

# Scan Features and Components



- Import a PDF onto an Existing Plan**  
 Enrich your plan by importing an image or PDF (e.g., an existing architectural plan). o Precisely overlay and align your scan with a reference document. Steps include:
  1. Access your existing plan
  2. Import the PDF file via the import button
  3. Adjust the imported PDF's scale to match your plan
  4. Activate the positioning mode. 
  5. Use the tools to move and rotate the PDF/image:
    - Drag the document on the plan.
    - Use the rotation tool to adjust orientation.
  6. Once positioning is complete:
    - Deactivate the move and rotate buttons.
    - Click "Save" for final positioning. 

- Notes:** Add notes in text, photo, voice file, or panoramic photo formats.

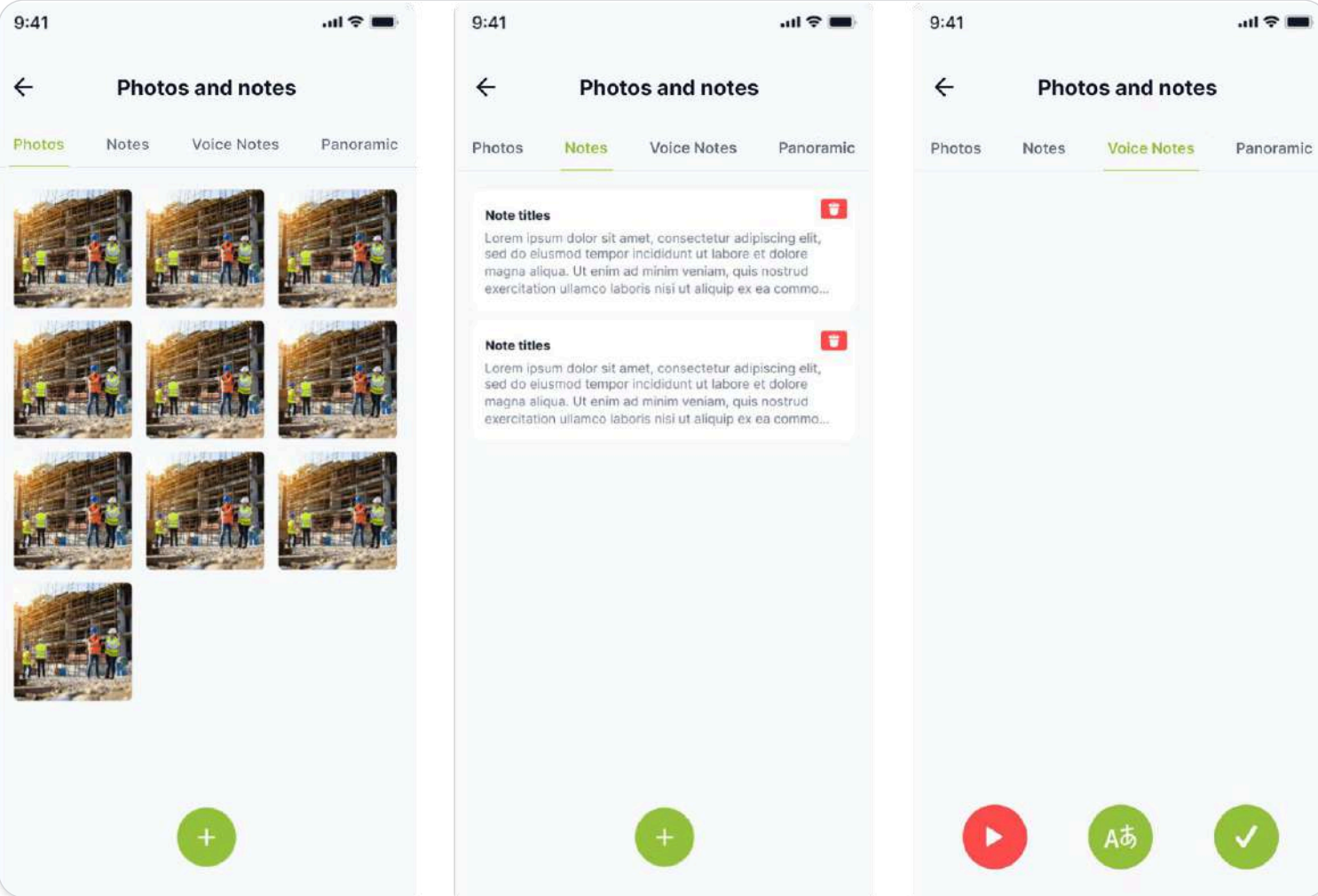

### ⇒ Annotations on Photos

The application offers an advanced annotation feature to enrich your images interactively and precisely. Accessible through the "Notes" interface, the annotation module provides a complete set of tools to personalize your visual comments.

The interface consists of several essential elements:

- An intuitive toolbar with drawing and annotation options
- Clear action buttons ("Close," "Comment," "Delete")
- A text field for adding detailed comments, where you can dictate your notes via voice command, which will automatically be converted into text
- Save and undo options



# Scan Features and Components

Users can:

- Draw directly on the image to highlight specific areas
- Add textual comments linked to the marked elements
- Document anomalies or points of interest
- Save their annotations for future reference

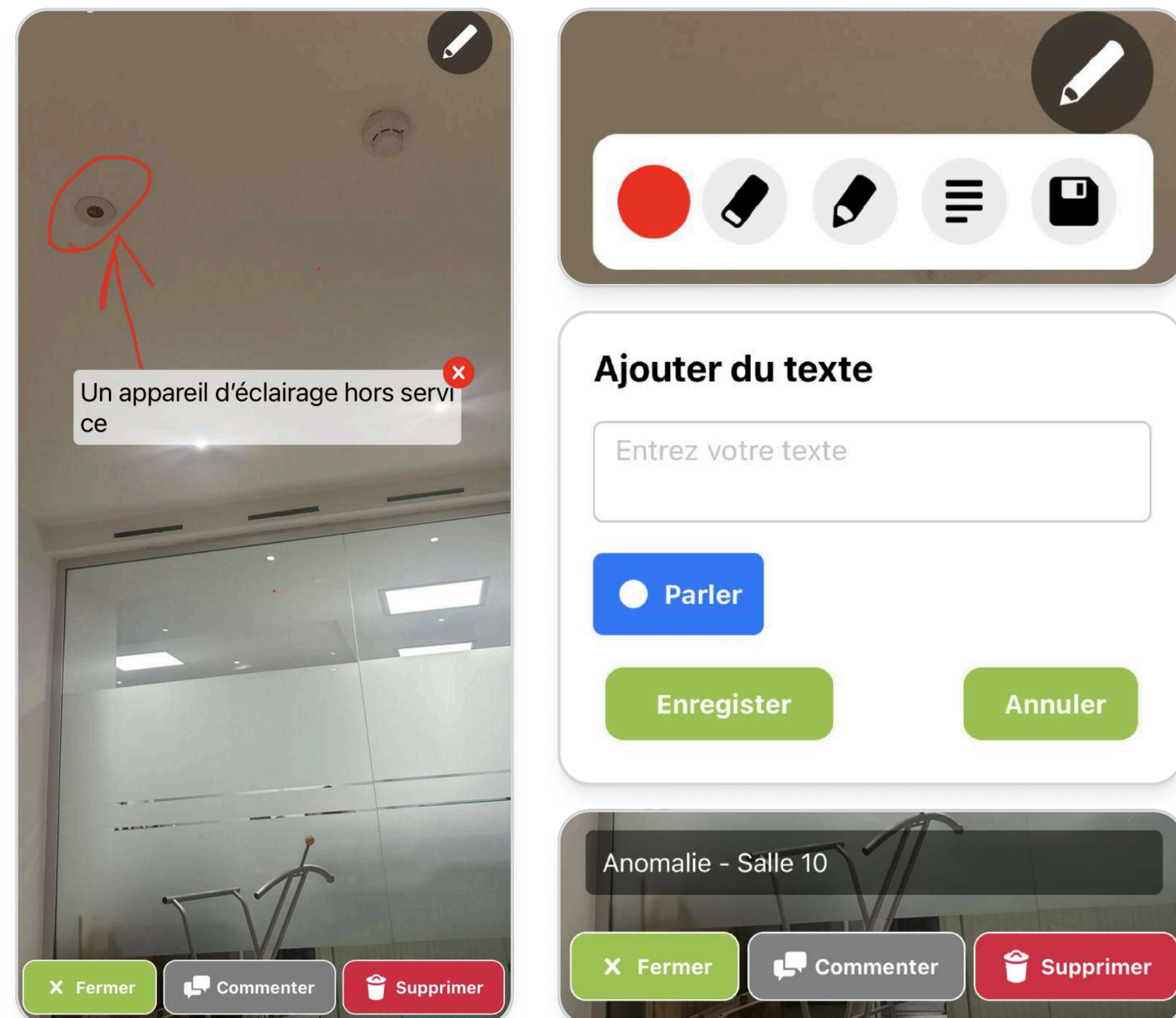

## 9. Statistics and General Data:

The "**Detail**" button provides a comprehensive summary of the plan's statistics and general data:

- **Key Statistics:** Area, perimeter, volume, number of rooms, doors, windows, and ceiling height.
- **General Data:** Creation date, floor, and geolocated address.

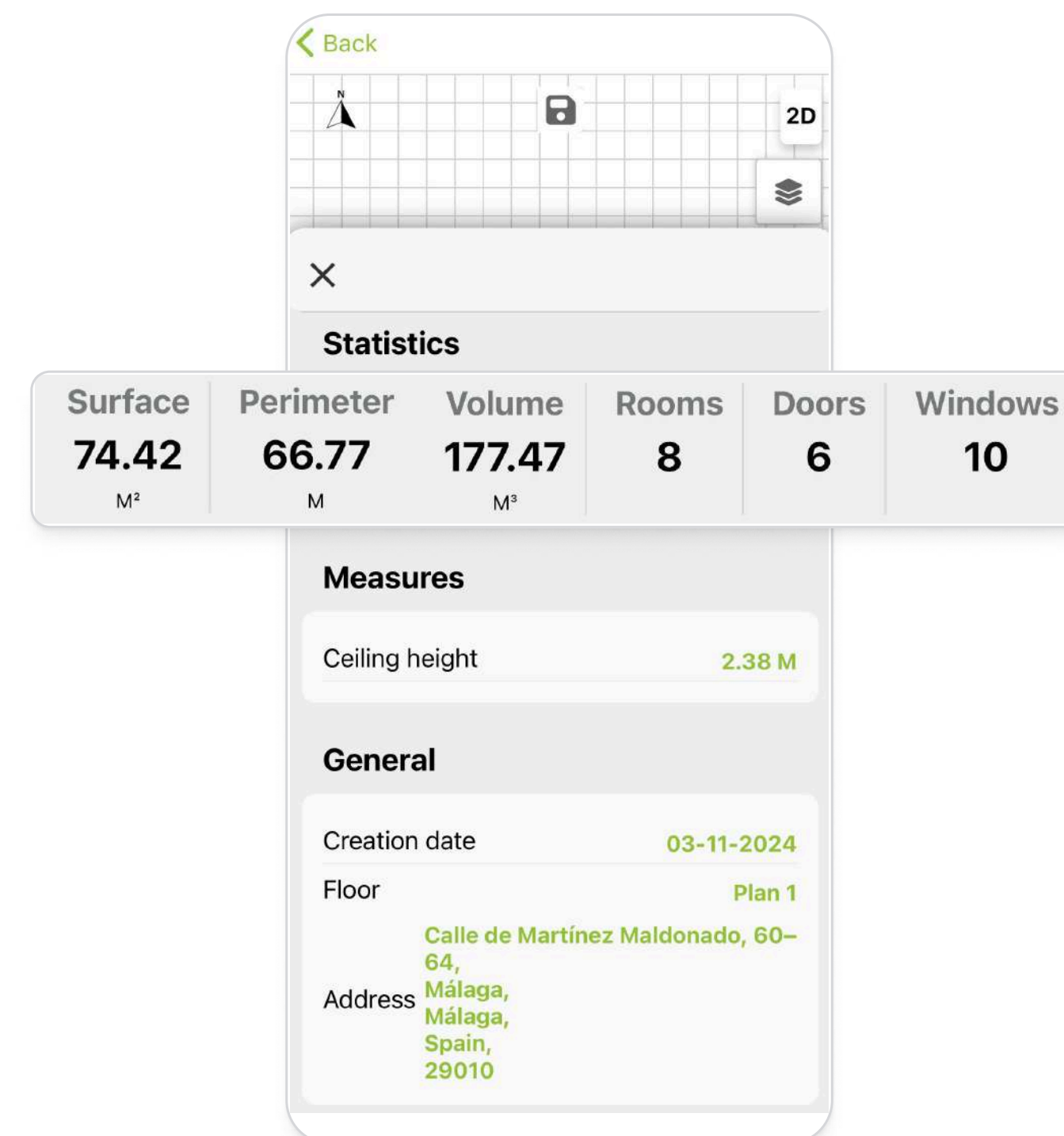

# Drawing Features and Advanced Options

MAKE.PLAN integrates a comprehensive range of drawing and editing tools that allow for precise and customized plan creation. Below is a detailed description of the available features:

## 1. Drawing Tools

A Pencil button provides access to various options for designing or modifying a plan:

1. **Wall:** Draw walls to structure your spaces.
2. **Door:** Add doors with precise dimensions.
3. **Window:** Insert windows and adjust their position.
4. **Sliding Door:** Combine a door and a window into a single element.
5. **Floor:** Define floor areas in the plan.
6. **Opening:** Draw any part detected as an opening in a section of the plan.
7. **Furniture:** Add furniture from the integrated library.
8. **Subdivide an Element:** Split the segments of a room into multiple wall sections.
9. **Cut a Floor:** Modify or remove sections of flooring.
10. **Fill:** Fill specific areas with colors or textures to differentiate elements.
11. **Line:** Draw custom lines on the plan.
12. **Column:** Add structural columns.
13. **Closet:** Insert closets into your plan for additional details.

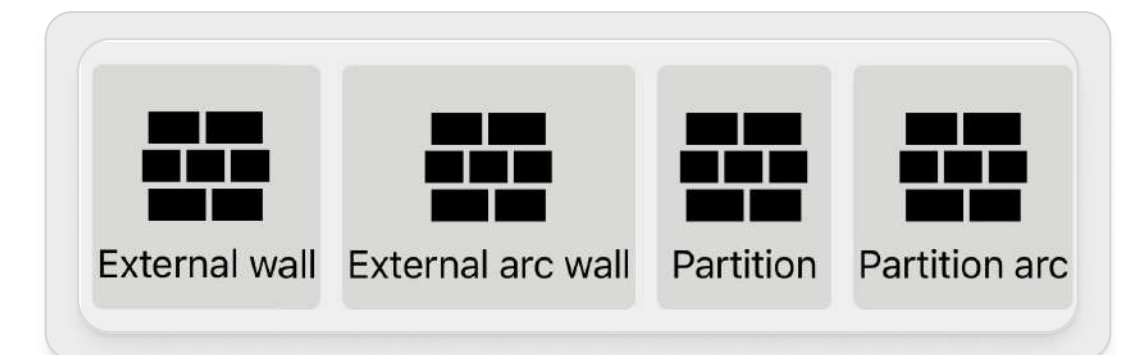
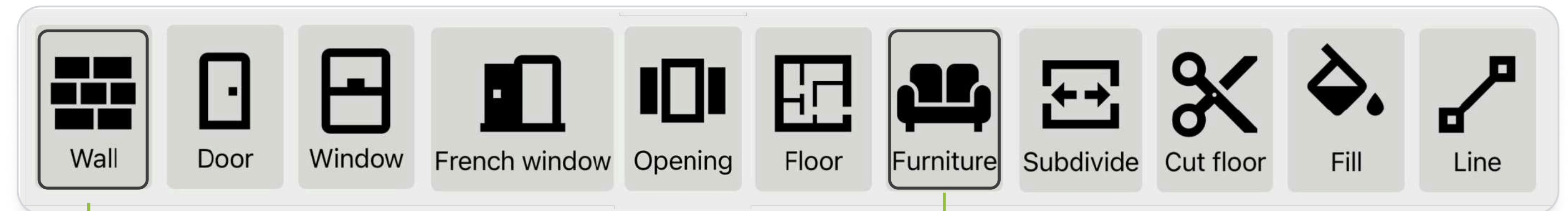
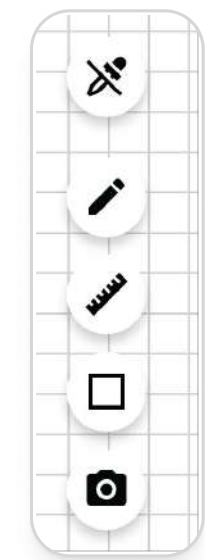

# Drawing Features and Advanced Options

## 2. Display Modes

To facilitate analysis and visualization, MAKE.PLAN offers multiple display options:

- 1. 2D:** A two-dimensional view of the plan with measurements and dimensions.
- 2. 3D:** A three-dimensional view to visualize models from different angles.
- 3. 360°:** Explore the scanned space as a virtual tour.



## 3. Layer and Element Management

### 1. Layer Management:

- a) Furniture:** Control the visibility of furniture placed in your space.
- b) Plan:** Manage the display of the base plan.
- c) PDF Plan:** Show or hide the architectural plan in PDF format

These layers can be activated or deactivated individually or in combination, enabling you to view your project according to specific needs.



### 2. Rotation :

- Furniture Rotation:** Adjust the orientation of furniture for better placement.
- Plan Rotation:** Modify the general orientation of the plan to better suit project requirements.

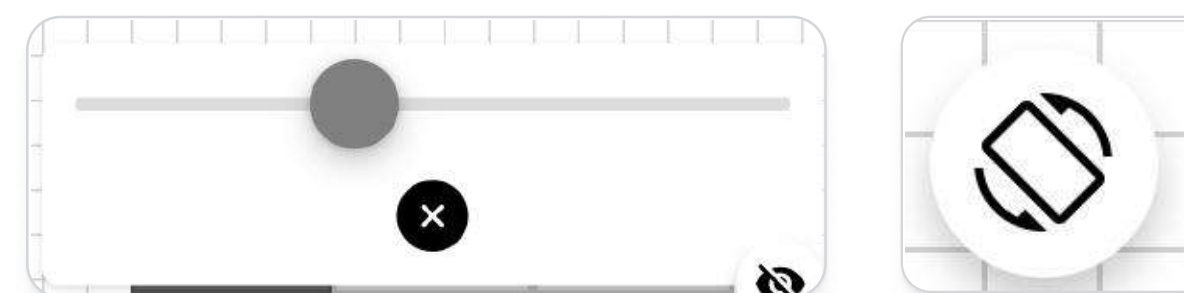
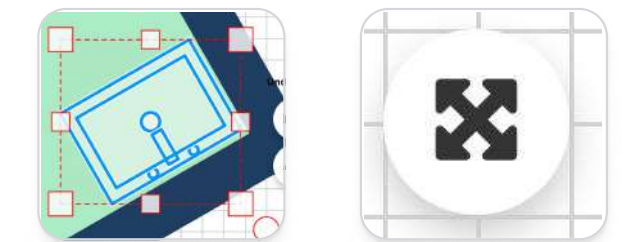

- 3. Hide Buttons:** Hide drawing tools and minimize the bottom bar to maximize the visible screen area.

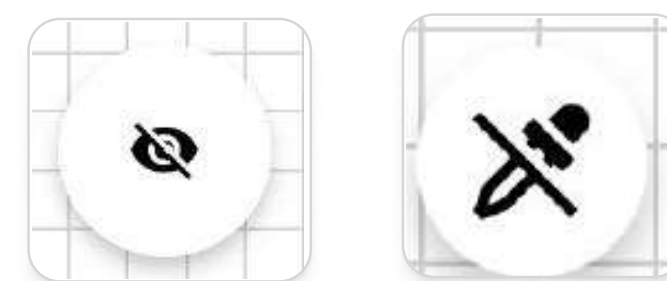

# Drawing Features and Advanced Options

## 4. Precise Measurements

- 1. Distance Measurement:** Calculate lengths between two points on the plan.
- 2. Surface Measurement:** Outline an area to determine its exact surface.

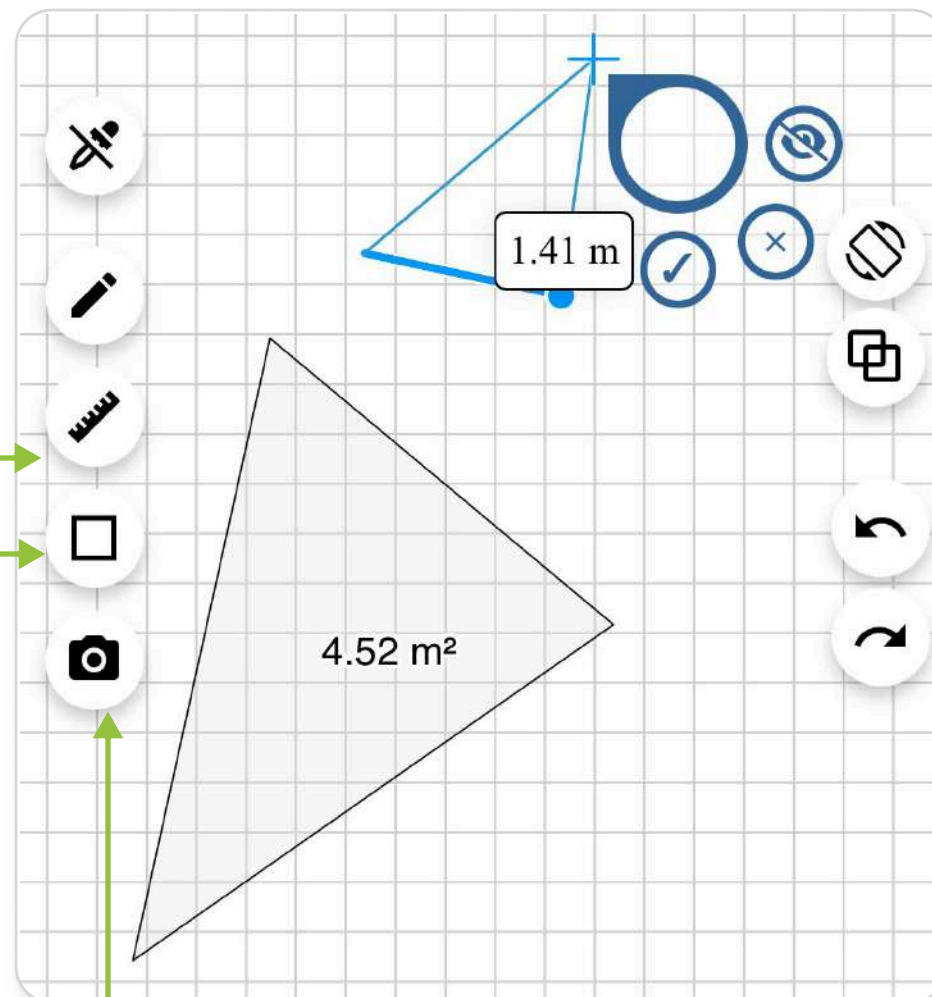

## 5. Plan Interaction

- 1. Take a Photo on the Plan:** Capture an image integrated directly into the plan, specifying the orientation and direction of the image.
- 2. Undo and Redo:** Revert actions or restore them using the undo and redo buttons.
- 3. Element Deletion:** Select and delete unwanted objects or elements from the plan.
- 4. Add Notes:** Add textual, voice, or photographic annotations to each element of the plan

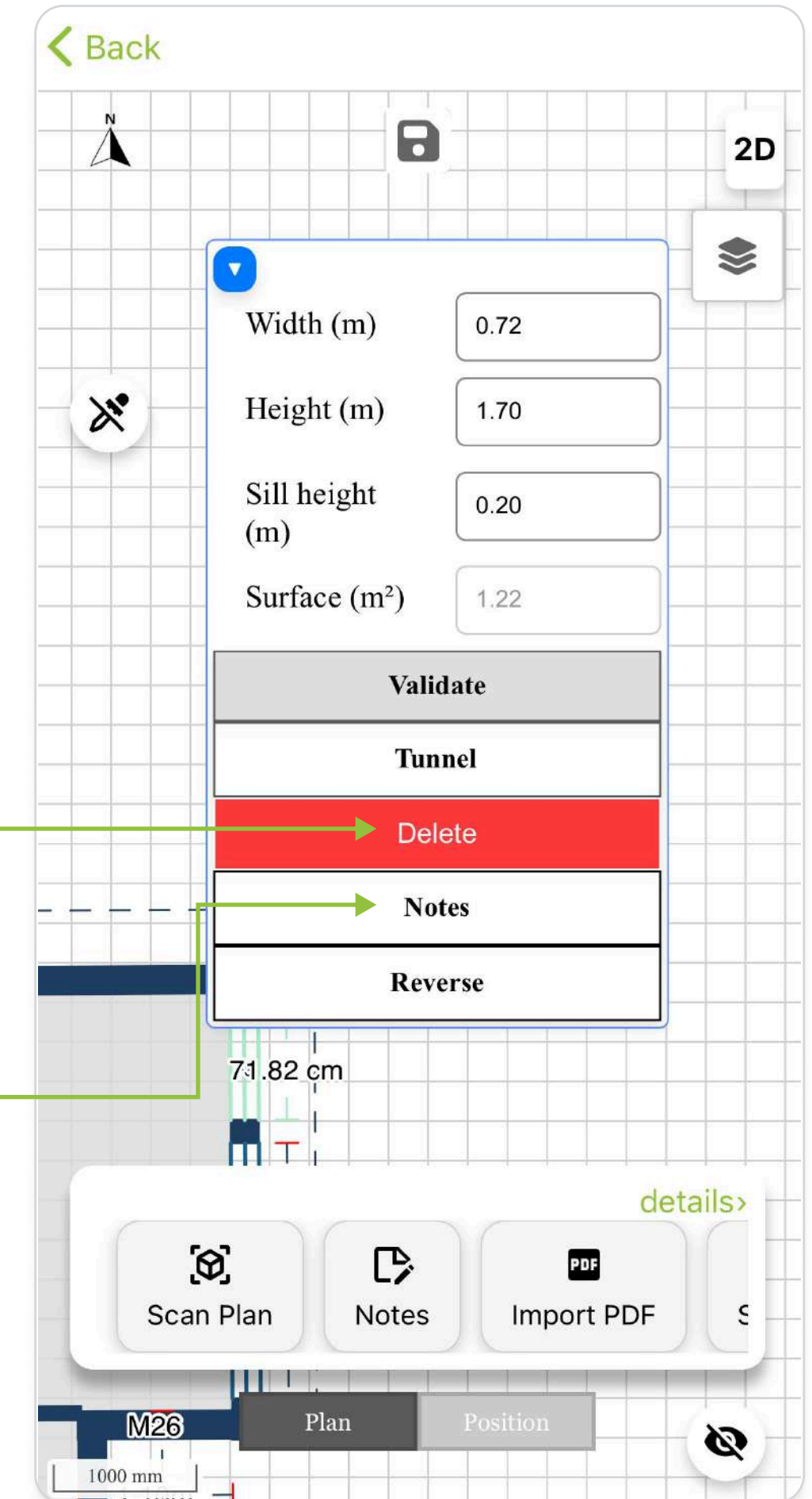

# Drawing Features and Advanced Options

## 6. Element Modification and Information

**1. Flip and Change Orientations:** Reverse or modify the orientation of elements (doors, windows, furniture, etc.).

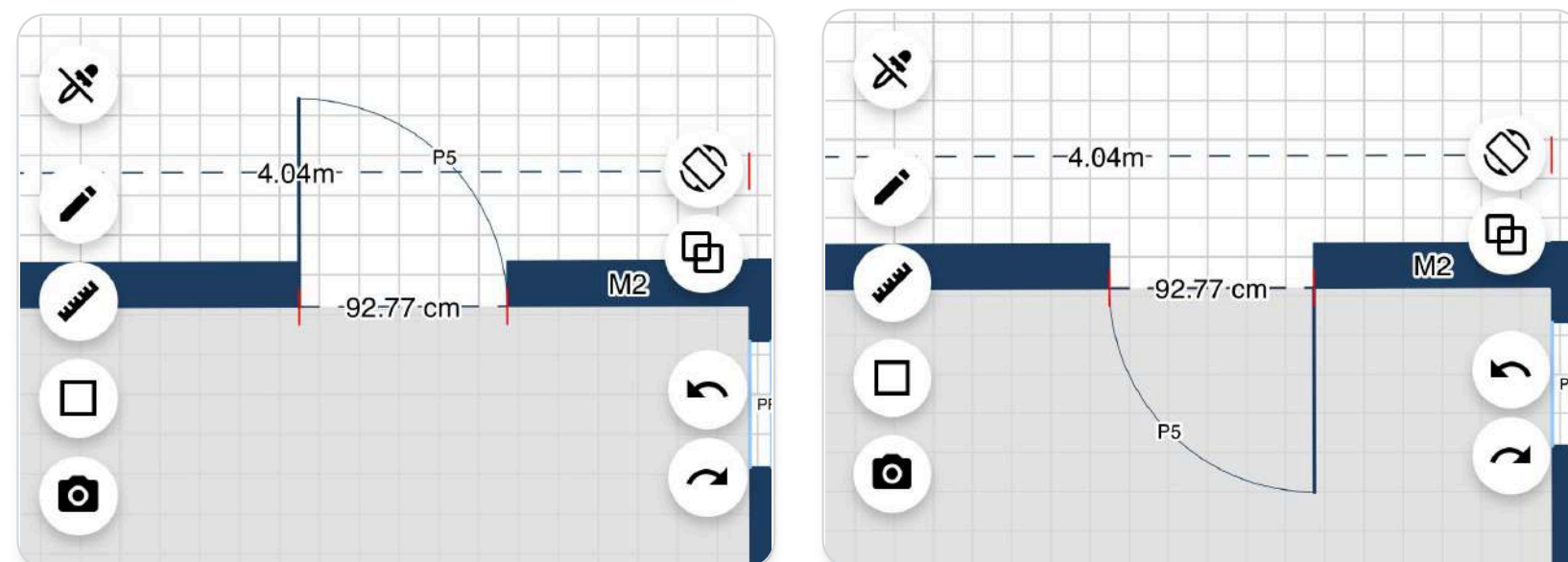

**Inverser**

**2. Detailed Information:** Access specific properties of each element (dimensions, position, material, etc.).

## 7. Compatibility with Digital Libraries

**MAKE.PLAN** allows users to insert BIM objects from digital libraries, enabling you to include physical and technical properties of various components in the plan.

## 8. Export Types

**1. Site Report:** Complete detailed reports to document scanned spaces.



Etat des lieux studio  
Etat des lieux T2/T3/T4  
Etat des lieux d'entrée  
Etat des lieux de sortie

**2. Exports:** The application allows you to export your plans in various formats to suit your needs:

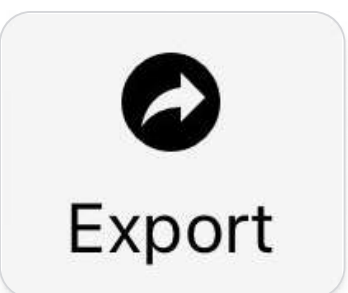

Technical Formats: :

- Image (JPEG)
- DXF
- IFC

PDF Documents:

- Plan
- Plan and Report
- Detailed Report
- BDNB Sheet
- Dressed Plan

# Drawing Features and Advanced Options

**Note:** For dressed plans (floor and full), you will be prompted to select the type of flooring from the following options: marble flooring, parquet flooring, or tiled flooring

Choisir le type du sol

Sol en marbre

Sol en parquet

Sol en carrelage



Retour Rapport de synthèse

Date de création: 03/11/2024  
Adresse: Calle de Martinez Maldonado, 60-64, Málaga, Spain, 29010

Hauteur sous Plafond :	2.38m
Surface :	77.25m²
Périmètre :	66.34m
Nombre de Pièces :	5
Nombre de Portes :	6
Nombre de Fenêtres :	10
Volume :	184.22m³

Détails des murs :

Mur	Surface	Surface Opaque	Orientation
M1	6.28 m²	5.04 m²	Non orienté
M17	3.62 m²	2.98 m²	Non orienté
M26	2.62 m²	2.62 m²	Non orienté
M6	0.86 m²	0.86 m²	Non orienté
M3	3.54 m²	0.34 m²	Non orienté
M5	1.24 m²	1.24 m²	Non orienté
M8	8.24 m²	7.31 m²	Non orienté
M10	0.97 m²	0.97 m²	Non orienté
M34	7.32 m²	7.32 m²	Non orienté
M14	5.69 m²	5.69 m²	Non orienté
M13	6.73 m²	6.31 m²	Non orienté
M22	1.2 m²	0.77 m²	Non orienté
M35	6.08 m²	4.69 m²	Non orienté
M7	8.54 m²	8.43 m²	Non orienté

Retour

2D

Export

- Image
- DXF
- IFC
- Plan
- Plan et Rapport
- Rapport détaillé
- Fiche BDNB
- Plan Habillé

Fiche BDNB

Description	Valeur
Classe du DPE	F
Adresse	Paris Expo Porte de Versailles, Paris, Ile-de-France, France, 75015
Identifiant unique des DPE de l'ADEME	2375E24342910
Type de DPE	dpe arrêté 2021 3cl logement
Type de bâtiment	appartement
Consommation annuelle 5 usages (ecs/chauffage/climatisation/cléage/auxiliaires) en énergie primaire	334
Emission GES totale 5 usages rapportée au m² (déduit de la production pv autoconsommée)	73
Type d'installation de chauffage (collectif ou individuel)	individuel
Type d'énergie pour le générateur de chauffage principal	gaz
Type de générateur de chauffage principal	chaudiere gaz standard
Présence de chauffage solaire	Non
Nombre d'installation de chauffage	1
Type de générateur de climatisation principal	Inconnu
Type d'installation d'eau chaude sanitaire (ECS) (collectif ou individuel)	individuel
Type de générateur d'eau chaude sanitaire (ECS) principal	chaudiere gaz standard
Présence d'ecs solaire	Non
Nombre d'installation d'ecs	1
Type de ventilation	Ventilation par ouverture des fenêtres
Type de production ENR pour le DPE	Inconnu
Classe d'inertie	Légère

# Settings Section

The **Settings** section of your application allows you to customize your experience and manage your personal information. Below is an overview of the main features available:

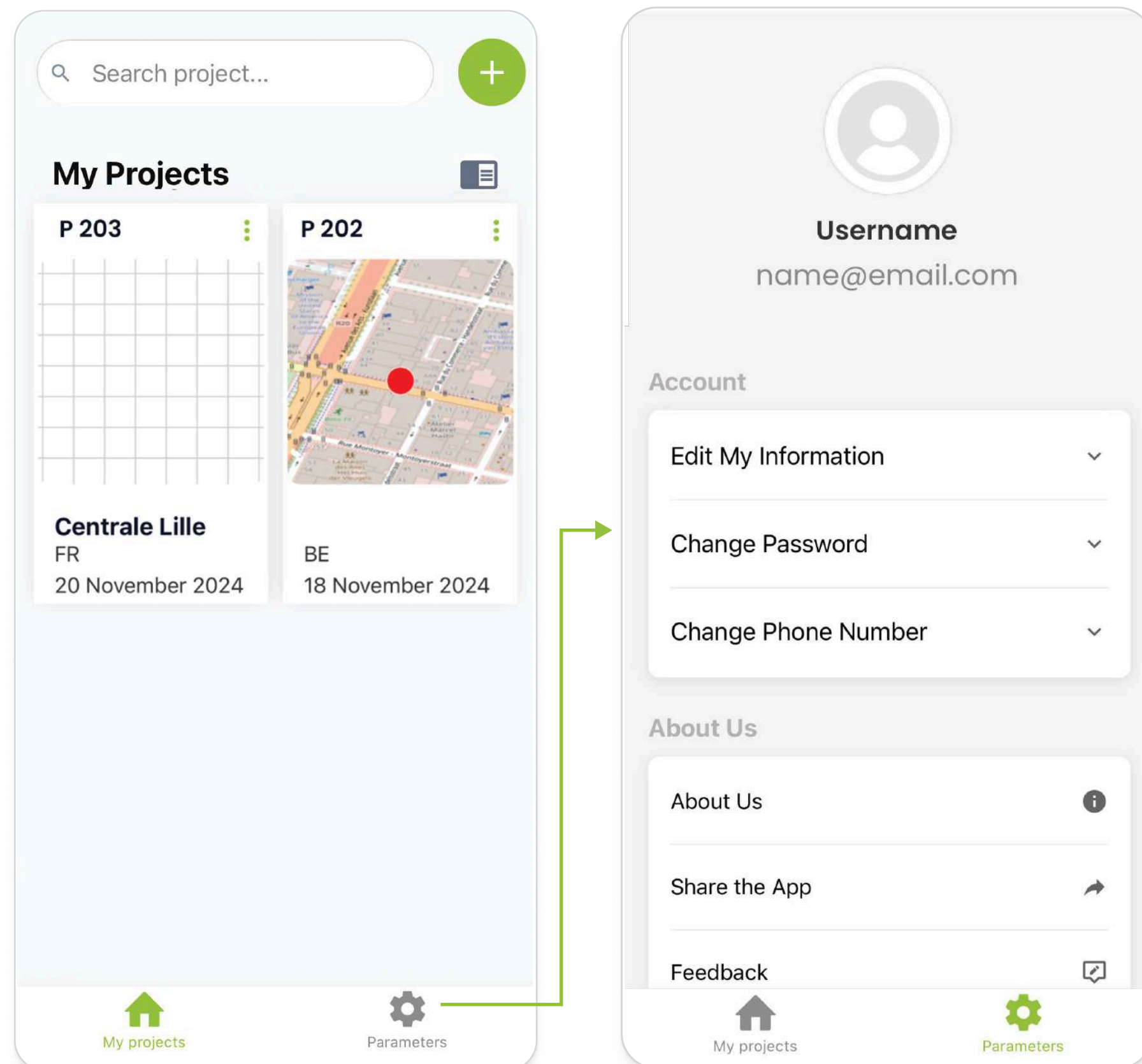

## 1. Account

Manage your personal information and account security:

- 1. Change My Information:** Edit your personal details (first and last name) and click Confirm to save changes.
- 2. Change Password:** Update your password by entering the current and new passwords, then confirm.
- 3. Change Phone Number:** Add or update your phone number.



# Settings Section

## 2. About

This section provides access to essential information and interaction features:

- 1. About:** View general information about the application.
- 2. Share the App:** Recommend the app to friends and family through your preferred channels (WhatsApp, email, etc.).
- 3. Feedback:** Share your experience with the app by:
  - Rating it on a scale of 1 to 5 stars.
  - Providing comments and suggestions in the dedicated space.
  - Your feedback is invaluable and helps us continually improve the app to better meet your needs.
- 4. Guide:** Access detailed application documentation to discover all its features and optimize usage.
- 5. Support:** A dedicated space to contact us directly if you have questions, encounter issues, or want to share your feedback. Our team is here to assist you in using the app.
- 6. Tutorial:** This section offers guided navigation to explore the various features of Make.Plan. These tutorials provide practical support for learning and making the most of the application.

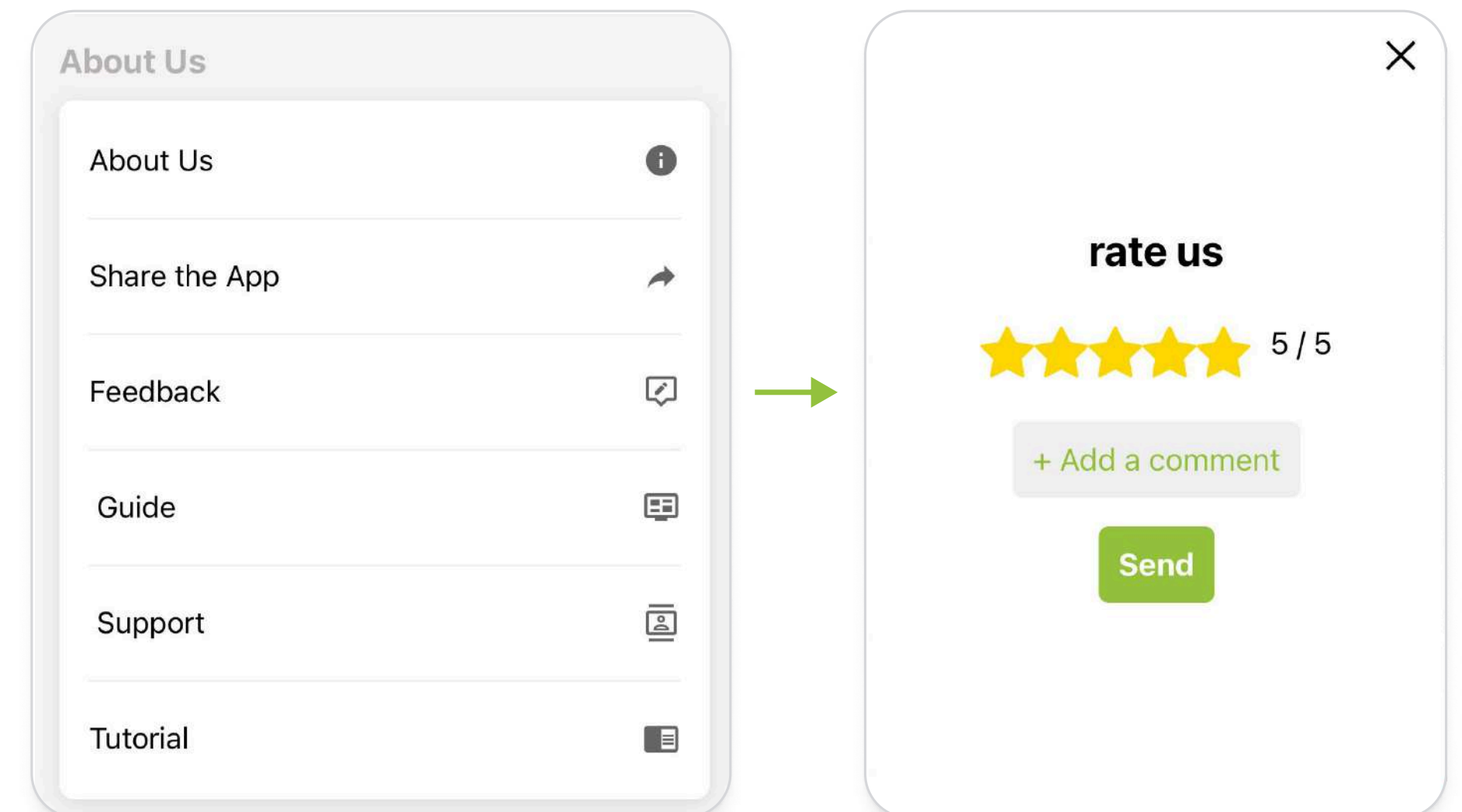



# Settings Section

## 3. Language Configuration

The application is available in multiple languages to suit your preferences. You can choose from the following:

- French
- English
- Spanish

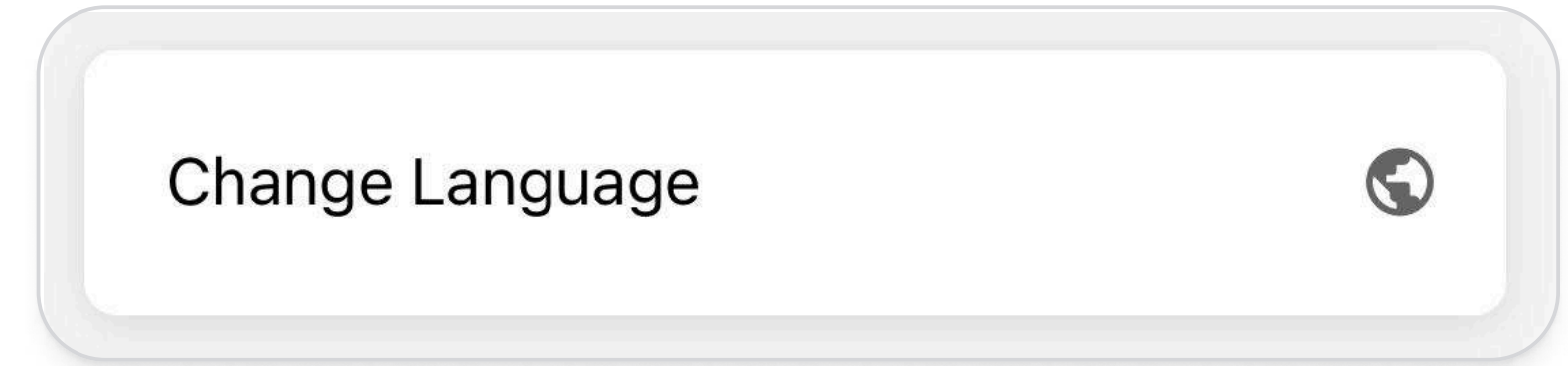

## 4. Account Actions

Important actions to manage or leave your account:

1. **Delete Account:** Permanently delete your account after confirmation  
**▲ Note: This action is irreversible.**
2. **Log Out:** Exit the application while retaining your data.

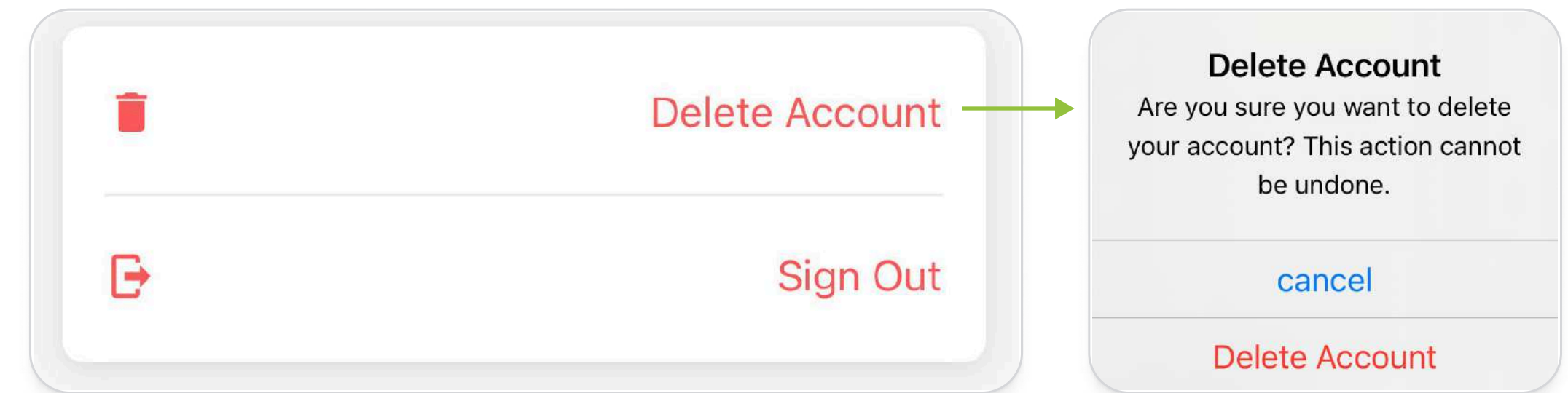

## 5. Useful Links

Access important documents:

- **Terms and Conditions:** Review the rules for using the application.
- **Privacy:** Learn how your personal data is protected.



# Support

If you encounter any difficulties accessing or using the Make.Plan application, we invite you to contact our Support team. You can reach them at the following address:

**<https://makeplan.tech/contact/>**